



INSTRUCTIONS FOR INSTALLATION, USE AND MAINTENANCE

PELLET BOILER

caldaia
Termoböiler®
Omnia

Read instructions carefully before installation, use and maintenance
The instruction manual is an integral part of the product.

LaminoxS.r.l. reserves the right to change the characteristics and data reported in the following document at any time and without warning in order to improve their products. This manual, therefore, cannot be considered as a contract with third parties.
Updated manuals and drawings are available at website www.laminox.com.

CAUTION, READ CAREFULLY

The TERMOBOILER models are a series of high-performance water boilers (over 92%), which exploits the combustion heat. The consequence of these performances is a low temperature of fumes exiting the boiler, around **60-110°C**. For this reason you must absolutely follow the requirements listed below :

- A. Build a fume-exhaust duct suitable for solid fuel condensation and resistant against condensation– vacuum pressure operation (N1) but airtight at a pressure up to 0.2 mbar. Refer to standard UNI 10683 :2012***
- B. install a 1” anti-condensation valve with 55°C opening.***
- C. Connect the room programmable thermostat to the external terminal board using a "NO" potential free contact.***
- D. Setting the boiler water temperature at 70°C.***
- E. We recommend not using the "chrono" mode on the boiler to prevent storage temperature from lowering and lack of domestic hot water when requested.***

IMPORTANT! If incorrect combustion occurs (check if white fume exits the chimney flue), switch the boiler off and immediately contact the T.A.S. to prevent condensate from propagating in the boiler.

Dear Customer, Thank you for choosing one of our products, which is a result of technological expertise and our continuous quest for superior products in terms of safety, reliability and performance. This manual contains all the information and helpful tips for using your product with maximum safety and efficiency.

IMPORTANT INFORMATION

This manual has been prepared by the manufacturer and is an integral and essential part of the product. In the event of sale or transfer of the product, always ensure the presence of the manual as the information it contains is addressed to the buyer and to all those various people involved in the installation, use and maintenance of the product. Carefully read the instructions and information contained in this manual before installation, operation and maintenance of the product. The instructions contained in this instruction manual guarantee the safety of persons and property and ensure efficient operation and a longer service life. The manufacturer declines all responsibility for damage caused by failure to observe instructions regarding installation, use and maintenance listed in the instruction manual, for unauthorised modifications or non-original replacement parts. Product installation and use must be carried out in accordance with the manufacturer's instructions and in compliance with European, national and local regulations. Installation, electrical connection, functional testing, maintenance and repairs are operations that must be performed by qualified and licensed personnel who must have appropriate knowledge of the product. Product installation must not be carried out close to walls made of wood or combustible material. For proper installation, you must observe the "Safety distances" section. Verify the exact flatness of the floor where you will install the product. When handling the steel parts of the cladding, use clean cotton gloves to prevent leaving fingerprints difficult to remove for the first cleaning. Boiler installation must be performed by at least two people. Connect the boiler to the mains only after proper professional connection to the chimney flue. The power cable plug must remain accessible after installation of the boiler. Only operate the boiler with regulation wood pellets (refer to the "FUEL" chapter). Never use liquid fuels to operate the pellet boiler or to stoke the embers present. Provide adequate ventilation in the installation area during operation. In the presence of operation failures, fuel supply will be interrupted. Re-start the unit after removing the cause of the failure. Discontinue use of the product in the event of failure or malfunction. Do not remove the safety guard located in the pellet tank. Any accumulated unburned pellets in the burner as a result of repeated failed ignitions must be removed prior to ignition. Pellet stove operation can cause very hot heating of the handles, the chimney flue and glass surfaces. Only touch these parts during operation when wearing protective clothing or with adequate aids. Because of the creation of heat on the glass, make sure that no persons unfamiliar with boiler operation stand in the installation area. Inform children of the precautions to be observed during product operation and of possible dangers. In the event of problems or misunderstanding of the instructions manual, contact the dealer. Placing objects which cannot withstand heat on the boiler or within the minimum required safety range is prohibited. Do not open the door during operation or operate the boiler with its glass broken. For product terms, limitations and exclusions, please refer to the warranty included with the product. In order to pursue a policy of constant product development and renewal, the manufacturer may make changes to it as deems appropriate without notice. This document is the property of the manufacturer and cannot be disclosed in whole or in part to any third party without the written consent of the company, which reserves all rights according to the law.

GUIDELINES AND STANDARDS

All our products are manufactured according to the following guidelines:

89/366 EEC
2004/108 EC
2006/95 EC
89/106 EEC

In compliance with the following standards:

EN 60335-1; EN 60335-2-102
EN 61000-3-2; EN 61000-3-3
EN 50366; EN 55014-1; 55014-2
UNI EN 303-5-2012

1	GENERAL STANDARDS	6
1.1	Fireplace or Chimney flue	6
1.2	Chimney pot.....	7
1.3	External air intake vent.....	8
1.4	Connection to the chimney flue	8
1.5	Preventing house fires.....	8
2	SPECIFICATIONS AND TECHNICAL DATA	9
2.1	Specifications	9
2.2	Technical data.....	9
2.3	Connections dimensions	9
2.4	Product identification data	9
2.5	Wiring diagram	10
3	FUEL	11
3.1	General notes	11
4	INSTALLATION	12
4.1	General notes	12
4.1.1	Installation in the presence of several appliances.....	12
4.1.2	Suitability of the installation rooms	12
4.1.3	Fume discharge system	12
4.2	Minimum safety distances	13
4.2.1	Corner installation (mm).....	13
4.2.2	Wall installation (mm).....	13
4.2.3	Distance from flammable ceilings and false ceilings (mm).....	14
4.2.4	Distance of fume exhaust system from flammable walls (mm)	14
4.3	Flooring protection	15
4.4	Minimum distances for positioning air intake vents.....	15
4.5	Fume exhaust duct.....	16
4.5.1	General notes	16
4.5.2	Tubes and maximum usable lengths.....	16
4.5.3	Holes for exhaust tube passage on walls or roof: recommended insulation and diameter 17	
4.5.4	Using a traditional type chimney flue	17
4.6	Using an external fume duct.....	18
5	ASSEMBLY	19
5.1	General notes	19
5.2	Unpacking	19
5.3	Electrical connection	19
5.4	Hydraulic connection.....	20
5.4.1	System filling.....	20
5.5	Boiler hydraulic diagram.....	21
5.5.1	Approximate hydraulic diagram	22
6	USE	23
6.1	6.1 Console description.....	24
6.1.1	Display functions	25
6.2	First ignition.....	25
6.3	Ignition and normal operation	26
6.3.1	Boiler start-up.....	26
6.3.2	No start-up	27
6.3.3	Normal Operation.....	27
6.3.4	Modulation based on boiler water temperature.....	28
6.3.5	Circulator.....	28
6.3.6	External thermostat	28
6.3.7	Domestic hot water production	29
6.3.8	Brazier cleaning	29
6.3.9	Shutdown	29
6.3.10	Interruption of power supply	29
6.3.11	Remote control.....	30

7	THE MENU	31
7.1	MENU 01 "WATER PRESSURE"	31
7.2	MENU 02 "CLOCK SET"	31
7.3	MENU 03 "CHRONO SET"	32
7.3.1	Menu 3-1 "ENABLE CHRONO"	32
7.3.2	Menu 3-2 "DAILY PROGRAMME"	33
7.3.3	7.3.3 Menu 3-3 "WEEKLY PROG-"	33
7.3.4	Menu 3-4 "WEEKEND PROGRAM"	35
7.4	Menu 04 "CHOOSE LANGUAGE"	35
7.5	Menu 06 "BUZZER MODE"	36
7.6	Menu 07 "INITIAL LOAD"	36
7.7	Menu 08 "BOILER STATUS"	36
7.8	Menu 09 "TECHNICAL CALIBRATIONS"	36
7.9	Menu 10 "PELLET TYPE"	36
7.10	Menu 11 "FIREPLACE TYPE"	36
8	SAFETY AND ALARMS	37
8.1	Safety devices	37
8.1.1	Fume exhaust pressure sensor	37
8.1.2	Boiler /structure temperature sensor	37
8.1.3	Smoke temperature sensor	38
8.1.4	Water temperature sensor	38
8.1.5	Water pressure switch	38
8.2	Alarms	38
9	WARNINGS AND MAINTENANCE	41
9.1	Opening the door	41
9.2	Disposal of ashes	41
9.3	Cleaning the ash container	41
9.4	Brazier cleaning	41
9.5	Combustion chamber cleaning	42
9.6	Smoke chamber cleaning	42
9.7	Exhaust system cleaning	42
9.8	Cleaning metal and ceramic parts	42
9.9	Cleaning the glass	42
9.10	Glass breakage	42
9.11	Replacing the remote control battery	43
9.12	Cleaning the smoke fan	43
9.13	Boiler inactivity	43
9.14	Routine and special maintenance	43

1 GENERAL STANDARDS

In general, we refer to regulations concerning "heat generators fed with wood and other solid fuels", UNI 10683:2012.

1.1 Fireplace or Chimney flue

Each device must have a vertical duct, called chimney flue, for outside release of combustion fumes produced by natural draft.

The chimney flue must meet the following requirements:

- It must not be connected to any other fireplace, stove, boiler, or hood of any kind (fig. 1).
- It must be properly spaced from combustible or flammable materials through an air gap or suitable insulating material.
- -The internal section must be uniform, preferably circular: the square or rectangular sections must have rounded corners with a radius of no less than 20 mm, maximum ratio between the sides of 1.5, walls as smooth as possible and without restrictions, curves must be regular and seamless, deviations from the axis no greater than 45° (fig-2).
- Each device must have its own chimney flue with a section equal to or greater than the diameter of the fume exhaust pipe of the boiler and a height no less than the one stated
- Never use two stoves, a fireplace and a stove, a pellet stove and a wood stove, etc. in the same room since the draft of one could damage the draft of the other. In addition, collective ventilation ducts that can cause vacuum in the installation environment are not permitted, even if installed in adjacent rooms and communicating with the installation room.
- Creating fixed or mobile openings on the chimney flue to connect equipment other than auxiliary devices is prohibited.
- Passing other air supply channels and piping for utilities through the chimney flue, even if oversized, is prohibited.
- The chimney flue should be equipped with a collection chamber for solid materials and any condensate, located below the mouth of the flue, so as to be easily opened and inspected from an airtight door.
- Whenever using parallel output chimneys, it is advisable to raise a bracing element. (fig.3).

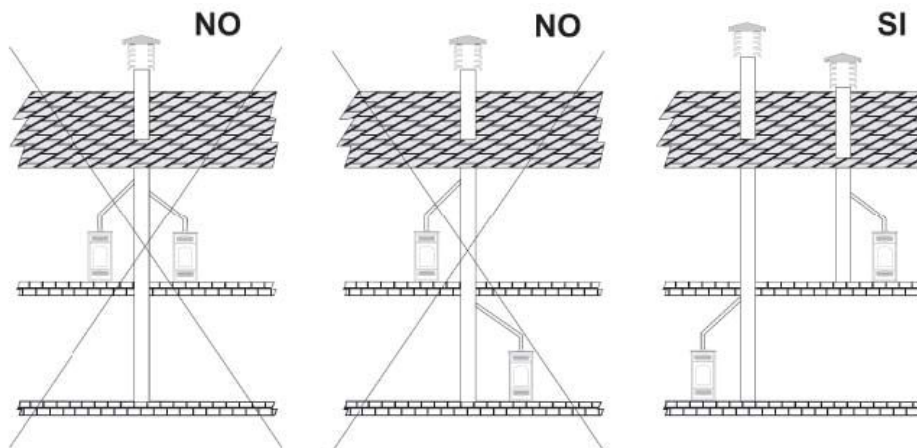

Fig 1

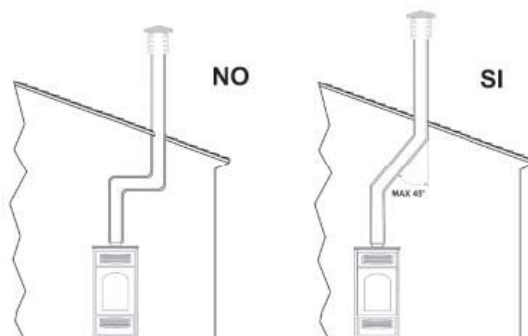

Fig.2

1.2 Chimney pot

The top of the chimney flue must be equipped with a device, called chimney pot, which facilitates dispersion into the atmosphere of combustion products.

The chimney pot must meet the following requirements:

- Its internal section and shape must be equivalent to that of the chimney flue.
- Have a useful outlet section at least double that of the chimney flue.
- The chimney protruding from the roof or which remains in contact with the outside (for example in case of open loft), must be covered with brick elements and well isolated, it must be constructed so as to prevent penetration into the flue of rain, snow, or foreign bodies and so that, in the event of winds in any direction and at any angle, it assures the discharge of combustion products (wind-proof chimney pot).
- The chimney pot must be positioned so as to guarantee an adequate dispersion and dilution of combustion products and, in any case, outside the zone of reflux. This zone can be of different sizes and shapes depending on the angle of slope of the roof, so it is necessary to adopt the minimum heights shown in *fig. 4* and *fig. 5*.
- The chimney pot must be of wind-proof type and exceed the height of the ridge, *fig. 4* and *fig. 5*.
- Any buildings or other obstacles that exceed the height of the chimney pot must not be close to the chimney pot itself (*fig. 4*).

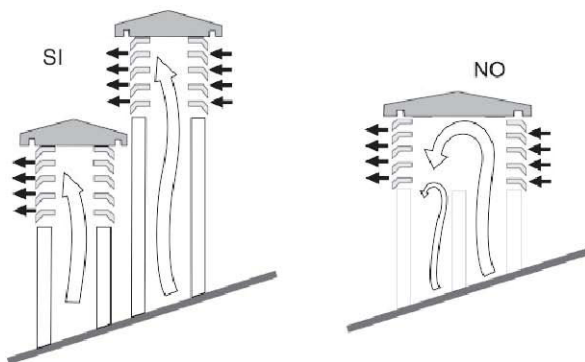

Fig. 3

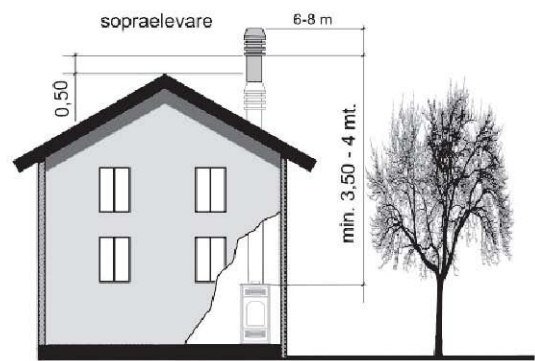

Fig. 4

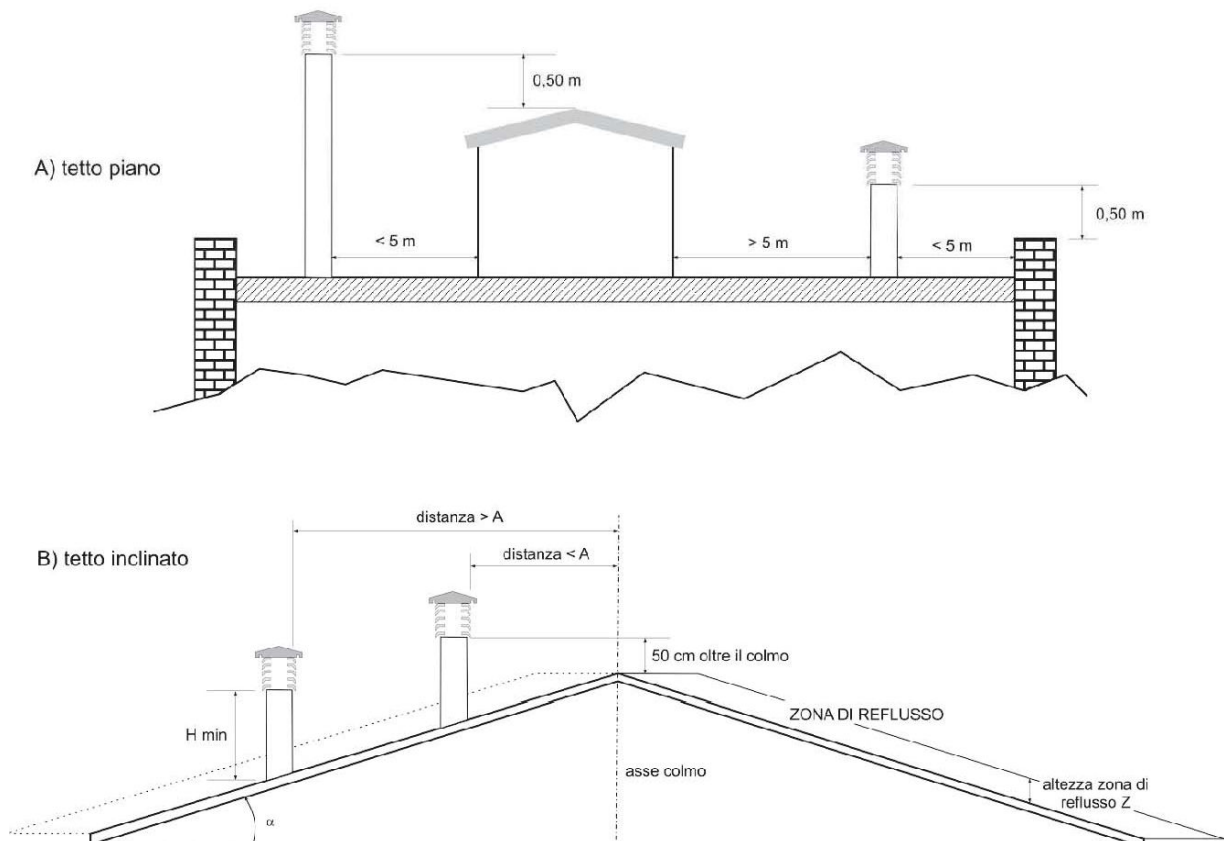

Fig. 5

Roof pitch ? [°]	Horizontal width of the zone of reflux from the axis of the ridge A[m]	Minimum height of the outlet from the roof Hmin =Z+0.50m	Height of the reflux zone Z [m]
15	1.85	1.00	0.50
30	1.50	1.30	0.80
45	1.30	2.00	1.50
60	1.20	2.60	2.10

Table 2

1.3 External air intake vent

- The boiler must have the air necessary to ensure smooth combustion operation and good environmental well-being.
- Make sure that the room where the boiler is installed offers sufficient ventilation and install an air supply duct from the outside with the recommended minimum section of 100 cm².
- The air intake vent must communicate directly with the installation room of the boiler, positioned so as to prevent it from being blocked and protected with a permanent non-lockable grid or other suitable protection provided that it does not reduce the minimum section.
- Air flow can also be obtained from a room adjacent to the installation room, provided that this flow can be carried out freely through permanent, non-closable openings communicating with the outside.
- With respect to the installation room, the adjacent room should not be put under vacuum with respect to the external environment as a result of a reverse draft caused by the presence in this space of another utility device or suction device. The room adjacent to the permanent openings must meet the requirements set out in the paragraphs above. The adjacent room cannot be used as a garage, for storage of combustible material or for activities involving the risk of fire.

1.4 Connection to the chimney flue

(see paragraph 4.5)

1.5 Preventing house fires

Installation and use of the boiler must be in accordance with the manufacturer's instructions and with local habitability regulations.

CAUTION: when a fume exhaust pipe passes through a wall or ceiling, particular installation methods must be used (protection, thermal insulation, distances from heat sensitive materials, etc.).

The fireplace connecting tube must never pass through a combustible surface.

Do not connect this unit to a chimney flue already being used by another device.

It is also advisable to maintain all combustible elements or flammable material such as beams, wooden furniture, curtains, flammable liquids, etc. outside the radiation area of the furnace and at a distance of at least 1 m from the heating block.

In the event that the surrounding space has coverings in combustible or heat-sensitive material, a protective membrane made of non-combustible insulating material must be interposed. If the flooring is made of combustible material, a non-combustible protective material that protrudes laterally and frontally from 15 cm to 30 cm must be provided at the mouth of the furnace.

For further information, refer to local requirements.

2 SPECIFICATIONS AND TECHNICAL DATA

2.1 Specifications

Pellet boilers are built to work with good quality wood pellets only (see chap. 3 fuel) and **must be** connected to the plumbing system.

This type of boiler must be installed in a closed, repaired and non exposed to weathering location

2.2 Technical data

Model or type	<i>Termoboiler Omnia 32</i>
Brazier power	<i>31.9 kW</i>
Hourly consumption (min/max)	<i>1.9-6.7 Kg/h</i>
Rated thermal input	<i>29 kW</i>
Reduced thermal input	<i>8.2 kW</i>
Performance at rated input	<i>91%</i>
Recommended draft	<i>10-12 Pa</i>
Pellet tank capacity	<i>70 Kg</i>
Power supply	<i>230 V / 50 Hz</i>
Max power absorbed	<i>1070 W</i>
Fumes outlet diameter	<i>100 mm</i>
External air intake vent – minimum useful section	<i>100 cm²</i>
Weight	<i>310 Kg</i>
Dimensions (LxPxH)	<i>1166x700x1403 mm</i>

2.3 Connections dimensions

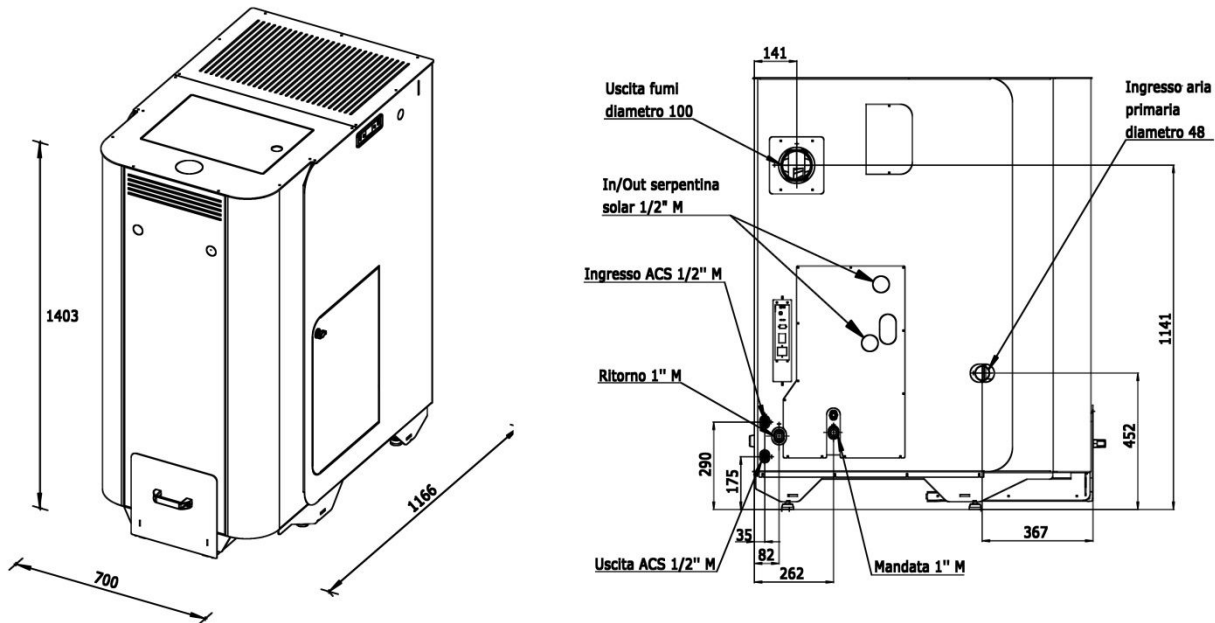

2.4 Product identification data

The technical label shows device data and performance. Tampering with, removing or lack of a technical label makes installation and maintenance operations difficult, due to the lack of product identification. In the event of damage, request a duplicate from our support centre. Given the importance of the data label, we recommend installing the boiler at a distance at which it is always visible.

	MADE IN ITALY		Potenza termica nominale : 29,0 kW
			Potenza termica minima : 8,2 kW
EN 303-5: 2012			Classe caldaia : 5
 Laminox S.r.l. Zona Industriale Callarella, 261-263 62028 SARNANO (MC)			Massima pressione di lavoro : 1,5 bar ammissibile
			Massima temperatura di lavoro : 80 °C ammissibile
Mod. TERMOBOILER OMNIA 32 SN 000001 - K 2016			Contenuto acqua : 130 l
			Tensione nominale : 230 V
IT			Corrente nominale : 4,6 A
			Frequenza nominale : 50 Hz
			Potenza elettrica nominale : 1050 W
			Combustibile da utilizzare : pellet di legno

2.5 Wiring diagram

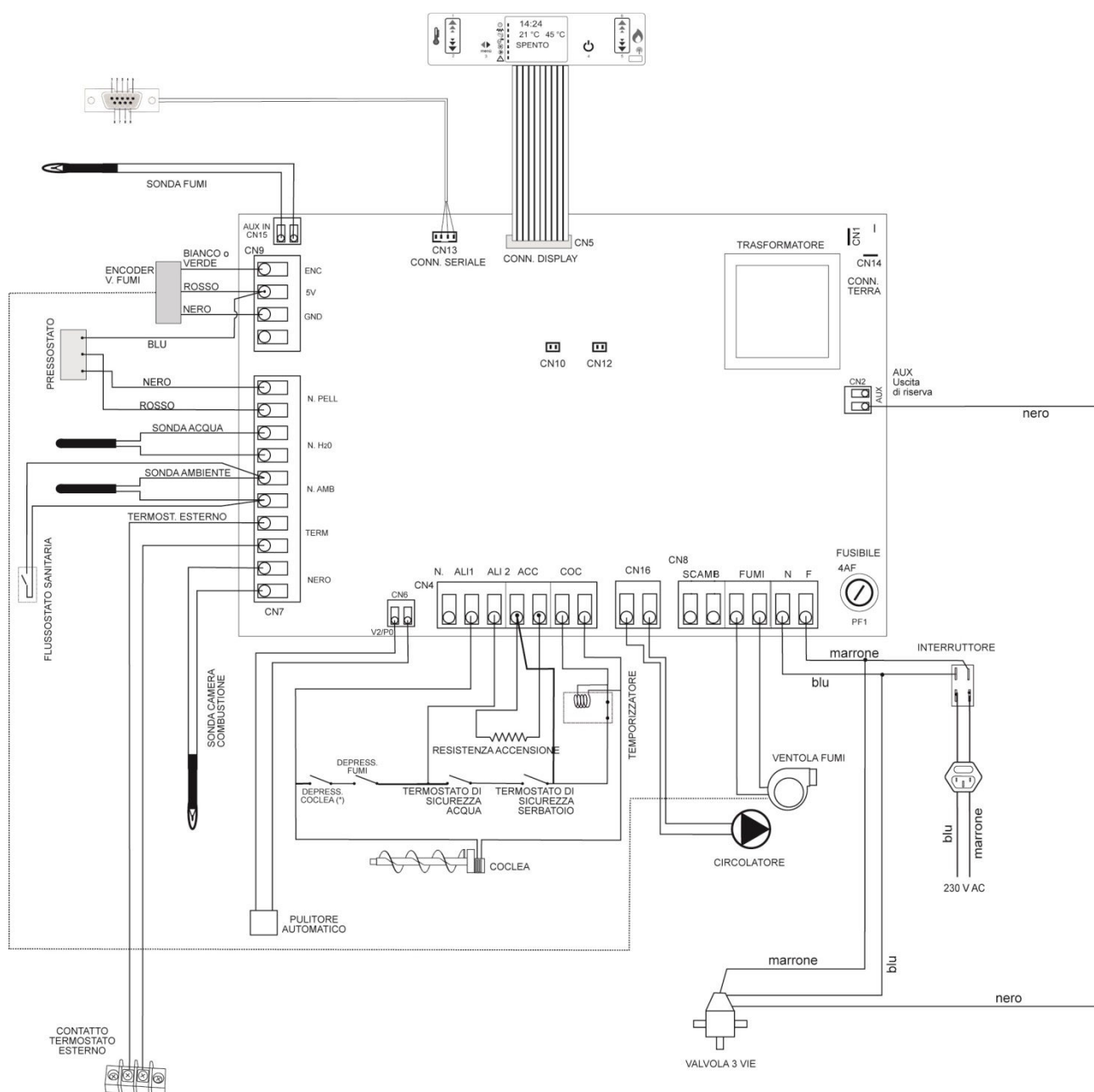

3 FUEL

3.1 General notes

The pellet boiler has been designed and certified to burn wood pellets only (*).

Wood pellets are a fuel obtained from the pressing of sawdust timber, extracted from the processing and transformation residues of dried wood material. The compactness of the product over time is guaranteed by a natural origin substance contained in the wood: lignin. The typical small cylinder form is obtained by extrusion. Various types of pellets with quality and characteristics that vary depending on the processing and type of wood species used are available on the market.

CAUTION: Always use certified quality wood pellets: e.g. DIN, DIN PLUS, ÖM 7135, Pellet Gold, Catas etc. The company does not guarantee proper boiler functioning with the use of low quality pellets.

Stoves and heating stoves are tested and programmed to ensure good performance and perfect quality operation with specific characteristic pellets:

Components:	wood
Length:	< 30 mm
Diameter:	6-6.5 mm
lower calorific value:	4.8 kWh/kg
Humidity rate:	< 8 %
Residual ash:	< 0.5 %

GOOD QUALITY pellets are smooth, shiny, slightly dusty and with regular length.

LOW QUALITY pellets are of varied lengths, dusty with vertical and horizontal splits.

Since pellet characteristics and quality greatly influence the autonomy, efficiency and proper operation of the boiler, we recommend:

- **AVOID** using pellets with dimensions different from that described by the manufacturer.
- **AVOID** using low quality pellets or pellets containing dispersed sawdust powder, resins or chemicals, additives or adhesives.
- **AVOID** using moist pellets.

The use of unsuitable pellets causes:

- Clogging of the brazier and fume discharge duct.
- Increased consumption of fuel.
- Decreased efficiency.
- Possible faulty operation of the boiler.
- Dirtying of glass.
- Production of unburned granules and heavy ash.

The presence of moisture in pellets increases the volume of the capsules and crumbles them causing:

- Feeding system malfunctions
- Poor combustion.

Pellets must be stored in a dry and sheltered environment, particular attention must be given to the handling of the bags to prevent their crushing, resulting in the formation of sawdust.

Boiler operation parameters may have to be altered when using quality pellets with dimensional and calorific characteristics different from those indicated. Contact an authorised support centre if necessary.

The use of poor quality pellets not in accordance with the manufacturer's instructions not only damages the boiler and compromises performance but may result in forfeiture of the warranty and company liability.

(*) Certain specifically-designed **omnivore models** can also burn washed, crushed and dried olive pits, ground and dried hazelnut and almond shells. As these fuels do not have standard characteristics it may be necessary to adjust the operating parameters. The technical data in the table always refers to wood pellets, using other products machine performance may change based on the heating power of the used fuel.

4 INSTALLATION

4.1 General notes

The heating system or appliance must be installed in order not to damage the building and other systems. The installer must strictly comply with standard UNI 10683:2012.

4.1.1 Installation in the presence of several appliances.

The presence of several appliances powered with different fuels, as well as hoods with or without extractor, must be evaluated during preventive checks and during the start up test in order to detect any variation compared to the design conditions or any aspect that cannot be detected during the design phase. The room must be well-ventilated according to the instructions of every single device. The external air intake vent must meet the requirements of paragraphs 1.3 and 4.4

4.1.2 Suitability of the installation rooms

- Installing the device inside rooms at risk of fire is prohibited.
- Outdoor installation in locations exposed to weathering or humid areas is **prohibited**.
- Boilers must be installed in a technical room. **It is forbidden to install them in open verandas or outdoors.**
- Installation in rooms containing other generators that collect air from the environment is prohibited (*par 6.4 UNI 10683:2012*).
- Sealed or closed operation appliances with external ducted combustion air intake can be installed only in bathrooms, bedrooms, and studios.
- The minimum volume of the installation room must be greater than 15 m³.
- Boiler installation must be carried out in a location which allows safe and easy use and simple maintenance. Said location must also be equipped with electrical grounding as required by law.

4.1.3 Fume discharge system

Every device must be connected to a fume discharge system, which ensures dispersion of combustion products into the atmosphere.

The combustion products must be discharged from the roofs. Direct wall discharge or towards closed spaces, even in open air, is prohibited.

The components must be made of material with A1 fire reaction class. In particular, the use of metal extendible and flexible hoses is prohibited.

CAUTION: ensure that the plug for electrical connection remains accessible after boiler installation.

4.2 Minimum safety distances

The following figures show the minimum safety distances which must always be guaranteed.

4.2.1 Corner installation (mm)

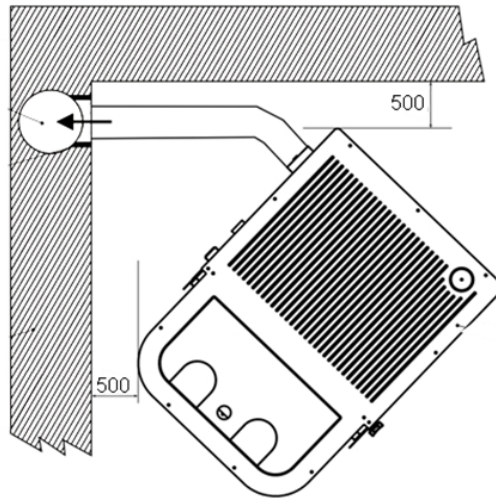

4.2.2 Wall installation (mm)

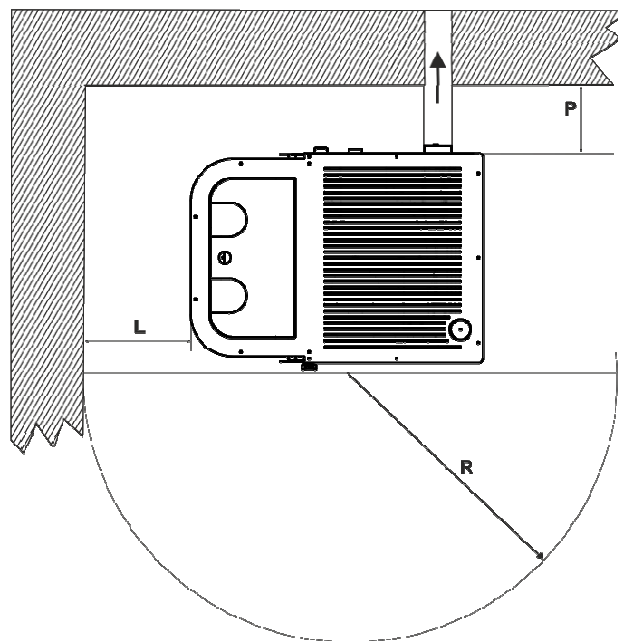

Safety distances from flammable material

- Minimum distance in air from the flammable rear wall **P= 500 mm**
- Minimum distance in air from the flammable side wall **L= 500 mm**
- Frontal distance from flammable material **R = 1000 mm**

4.2.3 Distance from flammable ceilings and false ceilings (mm)

Minimum mandatory distance from flammable material and from roof for maintenance **H= 800 mm**

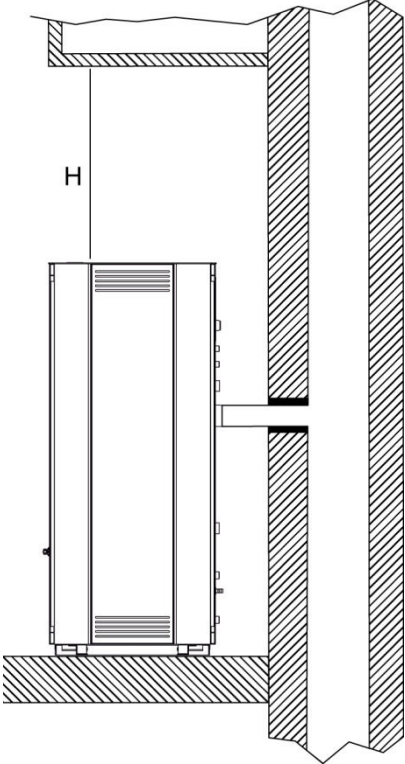

4.2.4 Distance of fume exhaust system from flammable walls (mm)

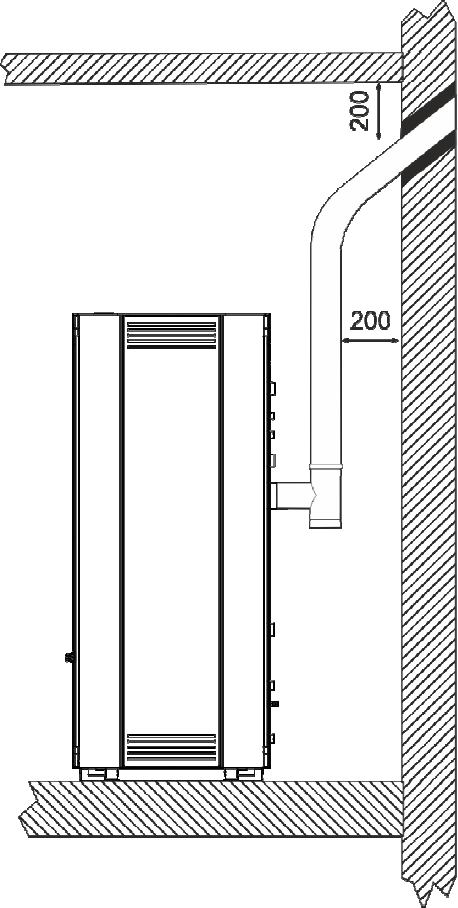

4.3 Flooring protection

In the event of valuable flooring or flooring that is sensitive to heat, moisture or is flammable, a floor protection must be used (e.g. sheet steel, marble or tile slabs).

Whichever type of protection selected, it must protrude at least 300 mm from the front and at least 150 mm from the sides of the boiler, withstand the weight of the boiler and have a thickness of at least 2 mm (fig. 6 and 7).

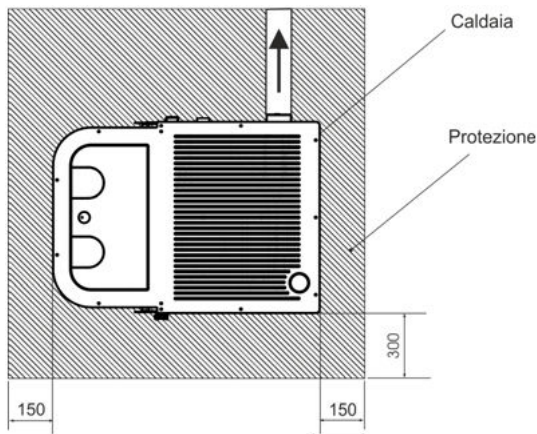

Fig. 6

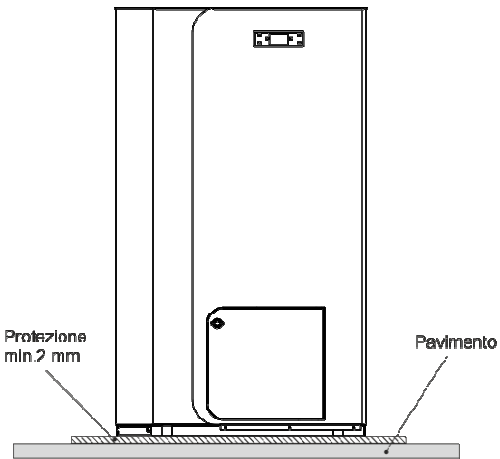

Fig. 7

4.4 Minimum distances for positioning air intake vents

Pellet boiler combustion air intake vents cannot be connected to an air distribution system or directly to a wall-mounted air intake vent.

Correct and safe positioning of the air intake vent must comply with the measures and requirements described in paragraph 1.3.

There are distances to be respected in order to avoid that combustion air be removed by another source; for example, a window opening can suck the air outside, making it miss the boiler.

The air intake vent must be located at least at:		
1.5 m	Under Horizontally away from	Doors, windows, fume exhaust outlets, air gaps, etc.
1.5 m		
0.3 m	Over Away from	Fume output
1.5 m		

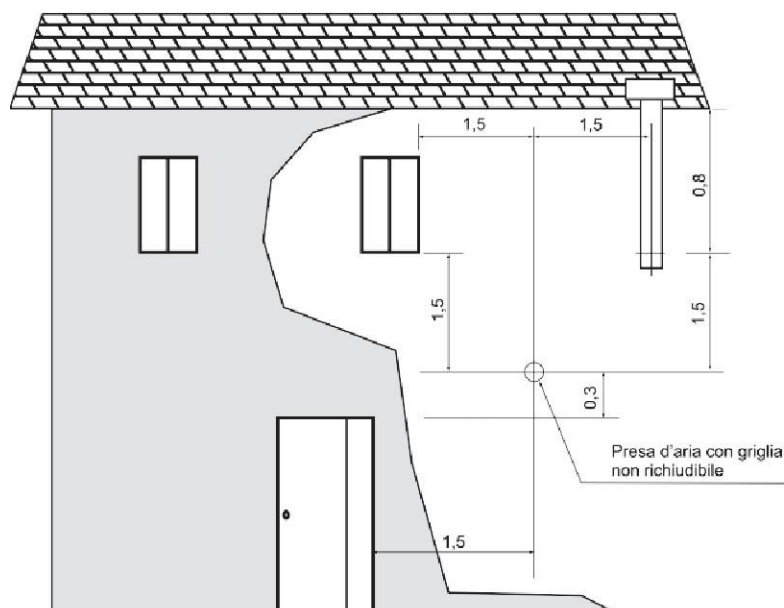

Fig. 8

4.5 Fume exhaust duct

4.5.1 General notes

CAUTION: the pellet stove is not like other stoves. Fume draft is forced thanks to a fan that maintains the pressure in the combustion chamber and slight pressure around the exhaust duct. Therefore, you must verify that the latter is completely watertight and properly installed, both from the point of view of function and safety.

Construction of the exhaust duct must be done by specialised personnel or companies, as reported in the following manual. Always create the exhaust system so that periodic cleaning is assured without having to dismantle any parts.

Tubes must **ALWAYS** be sealed with silicone (**not cemented**) that maintains resistance and elasticity characteristics at high temperature (250°C) and are to be secured with a Ø3.9mm self-tapping screw.

- The installation of shutters or valves which may obstruct the passage of flue gas is **prohibited**.
- Installation in a chimney flue where exhausted flue gas or vapours from other equipment (boilers, hoods, etc.) is **prohibited**.

4.5.2 Tubes and maximum usable lengths

All the components must be made of material with A1 fire reaction class UNI EN 13501-1. In particular, the use of metal extendible and flexible hoses is prohibited.

Double-wall steel tubes with internal nominal diameter of **80 mm** or **100 mm** (for tubes inside the chimney flue max 150 mm) must be used.

The male-female connection collars must be at least 50 mm long.

Tube diameter depends on the type of system. The boiler has been designed for Ø 80 mm and Ø 100 mm tubes (check the technical data sheet of the selected model). As can be seen in the table below, a double-wall Ø 100 mm tube may be necessary in some cases and models.

Type of systems	With double-wall tube Ø 80 mm	With double-wall tube Ø 100 mm
Minimum length	1.5 m	2 m
Maximum length (with 3 90° curves)	4.5 m	8 m
For installations situated over 1200 m above sea level	-	Mandatory
Maximum number of curves	3	4
Horizontal sections with min. 5% incline	2 m	2 m

NOTE: load losses of a 90° curve can be equated with those of 1 metre of tube; the serviceable T-connection is to be considered as a 90° curve.

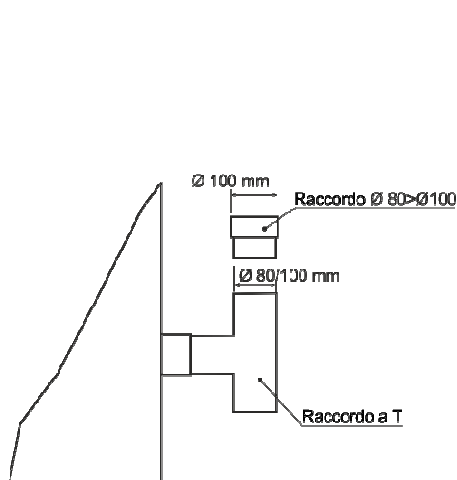

Fig. 9

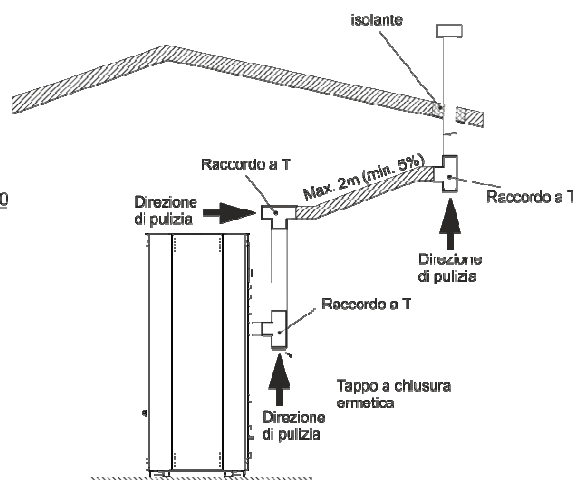

Fig. 10

4.5.3 Holes for exhaust tube passage on walls or roof: recommended insulation and diameter

Once the location of the boiler has been decided (*paragraph 4.1*), you will have to drill the hole for passage of the fume exhaust tube. This varies depending on the type of installation (therefore on the diameter of the drain pipe, see 4.5.2) and type of wall or roof to pass through (*tab.3*).

The insulator must be of mineral origin (rock wool, ceramic fibre) with a nominal density greater than 80 kg/m³.

	Insulation thickness [mm]	Fume exhaust tube diameter [mm]	
		Ø80 19 kW	Ø 100 From 24 kW
		Diameter of holes to be created [mm]	
Wooden wall, or wall which is flammable or has flammable parts	100	280	300
Concrete wall or roof	50	180	200
Brick wall or roof	30	140	160

4.5.4 Using a traditional type chimney flue

If you wish to use an already existing chimney flue, it is advisable to have it checked by a professional chimney sweep to ensure that it is watertight. This is because fumes, being slightly pressurised, could infiltrate in cracks of the chimney flue and invade living spaces. If an inspection finds that the chimney flue is not perfectly intact, it is advisable to intubate it with new material. If the existing chimney is large, we recommend inserting a tube with a maximum diameter of 150 mm. It is also advisable to insulate the fume exhaust duct. *Figs. 11 and 12* demonstrate the solutions to adopt if you want to use an existing chimney flue.

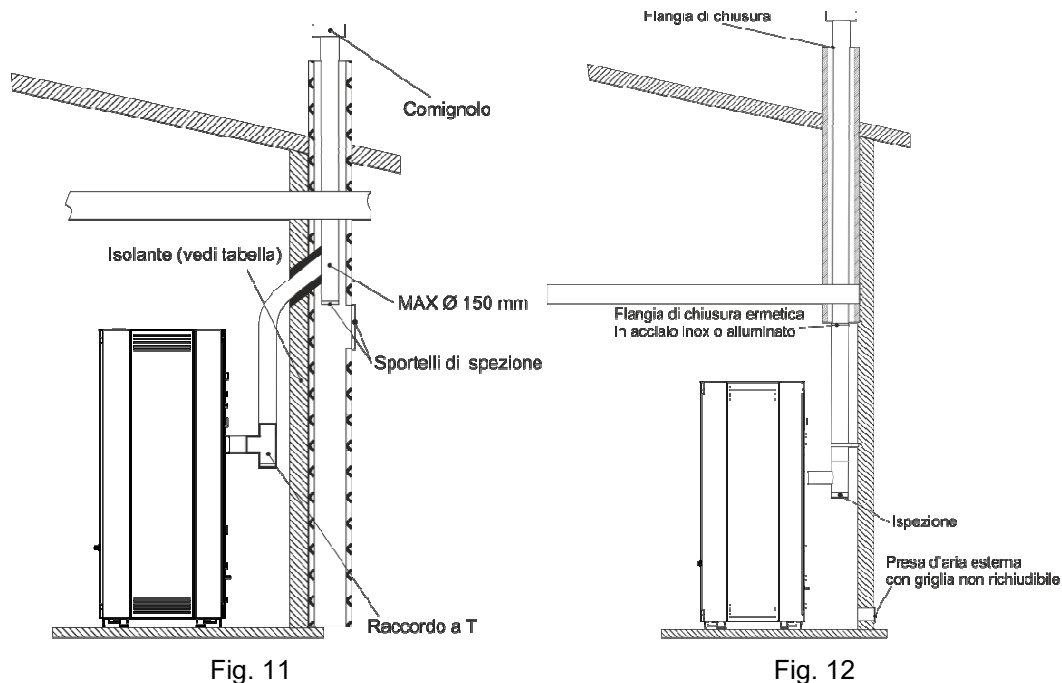

4.6 Using an external fume duct

An external fume duct can be used only if it meets the following requirements:

- For the ducts, only insulated tubes (double wall) in stainless steel, secured to the building (*fig.13*) must be used.
- An inspection area must be created at the base of the duct for performing periodic checks and maintenance.
- The duct must be equipped with a wind-proof chimney pot and observe the distance "d" from the ridge of the building as described in *par. 1.2*.
- *Fig. 13* shows the solution to be utilised should you wish to use an external fume ducts.

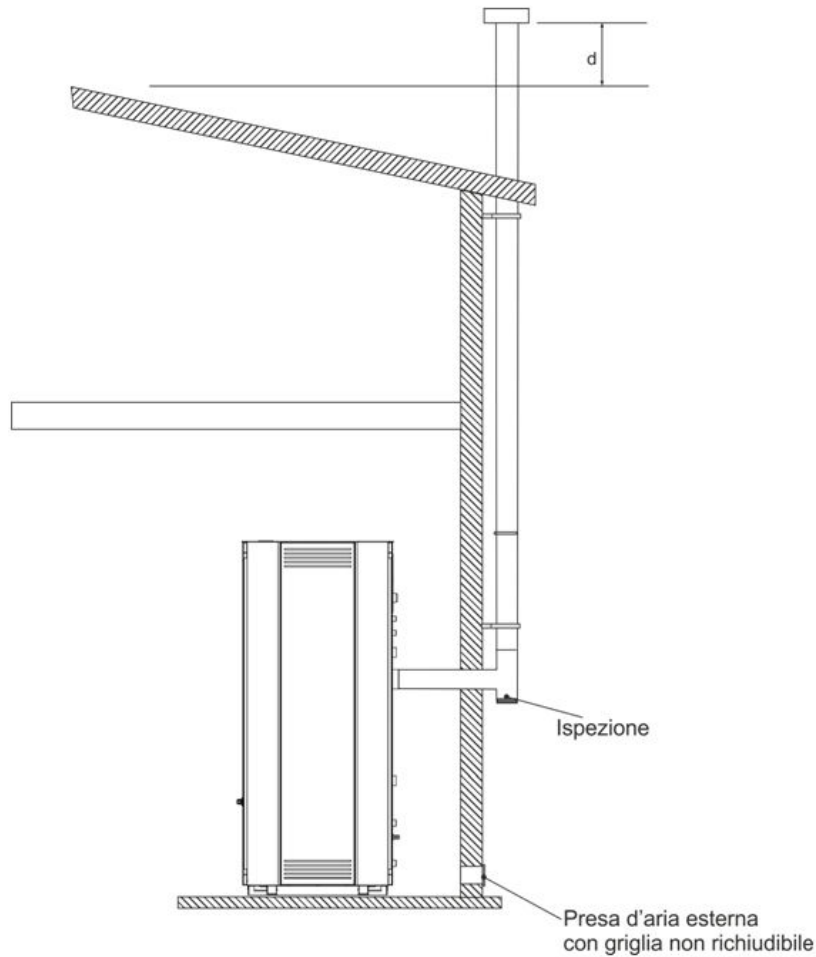

Fig. 13

5 ASSEMBLY

5.1 General notes

Here are some general recommendations to follow in order to prevent accidents or damage to the product:

- Unpacking and installation must be performed by at least two people.
- All handling operations must be carried out using appropriate means and in full compliance with safety regulations.
- The positioning of the packed product must be maintained in accordance with the guidelines supplied by pictograms and written on the packaging.
- If using ropes, straps, chains, etc., make sure they are suitable for the weight to be unloaded and are in good condition.
- When moving the package, move with slow and continuous movements to avoid tearing the ropes, chains, etc.
- Do not tilt excessively in order to avoid overturning.
- Do not stand within range of the loading/unloading means (forklifts, cranes, etc.).

5.2 Unpacking

Unpack the product being careful not to damage or scratch it. Remove the accessory package and any pieces of polystyrene or cardboard used to block removable parts, etc. from the boiler furnace. Also remember not to leave packaging components (plastic bags, polystyrene, etc.) within the reach of children, as they could be potential sources of danger. Dispose of them according to regulations.

5.3 Electrical connection

The boiler is supplied with a power cable that must be plugged into a 230V 50Hz outlet.

Outlet connection in the rear of the boiler is illustrated in Figure 14.

Absorbed power is indicated in the "SPECIFICATIONS AND TECHNICAL DATA" chapter of this manual.

By law, the system must be properly grounded and with a differential circuit-breaker.

Make sure that the electrical power cable does not come into contact with hot parts when set in its final position.

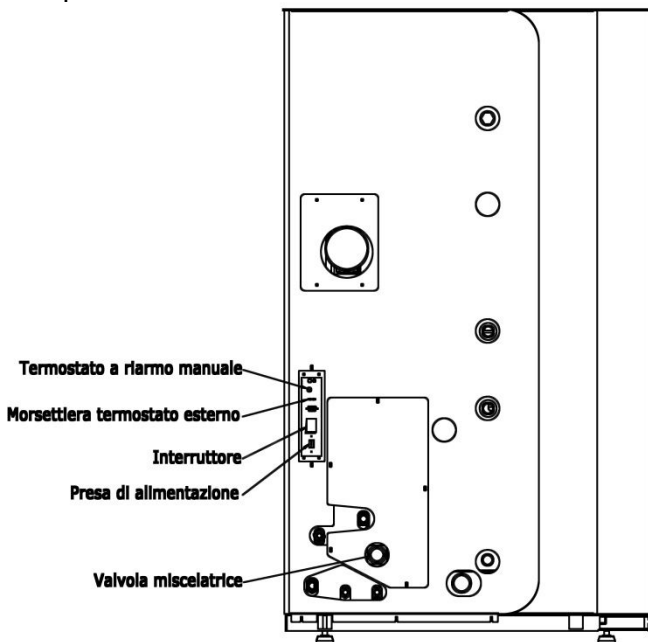

Fig. 14

CAUTION: ensure that the plug for electrical connection remains accessible after boiler installation.

5.4 Hydraulic connection

Connection of the boiler to the hydraulic system must be exclusively performed by qualified personnel, who is able to perfectly perform the installation, complying with the regulations in force in the Country of installation.

If the installation of the boiler requires interaction with another pre-existing system equipped with another heating device (gas boiler, methane boiler, gasoline boiler, etc.), contacting qualified personnel able to respond to the conformity of the system, according to the requirements of the law in force regarding the subject, is more recommended.

The company denies any liability in case of damages to property or persons or in case of no or incorrect operation if the aforementioned warnings are not complied with.

Caution: To connect the delivery pipe, return pipe, refilling pipe and drains arrange flexible hoses at least 70 cm long and shut-off shutters in order to isolate the machine from the water system should moving it to perform routine/special maintenance be required.
Connect the thermal safety drain of the machine to an appropriate drain funnel with no shut-off valves.

In case of thermal safety drain valve operation, the water must be free to flow without causing damage to persons and built-up area.

When the instrument is fully operational it produces hot water at a temperature necessarily lower than the boiling one and therefore the thermal system must be designed in compatibility with the machine specifications.

During installation and operation take into account that disposal of the minimum power delivered by the machine must be ensured.

Make sure that the thermal hydraulic system is fitted with an additional and adequate closed appropriately dimensioned expansion vessel.

For the installation of an additional expansion vessel take into account that usually 1 litre of vase compensated 10 litres of system and at least 1 litre is always dedicated to the water inside the boiler. The expansion vessel inserted inside the device is pre-charge at the pressure indicated in the plate, adjust the pre-charged pressure of the expansion vessels to the operating pressure of the thermal system.

We recommend installing a 1" anti-condensation valve with 55 °C opening and softener systems.

It is best to keep in mind that deposit drastically lower performance due to their extremely low thermal conductivity.

5.4.1 System filling

Before performing the boiler connections thoroughly wash the thermal system (pipes, heating bodies, etc.) with appropriate paint or deposit removers able to remove any residues which may compromise the correct operation of the boiler.

Hydraulic connections must be performed rationally using the connections of the boiler. The boiler safety valve drain must be connected to a drain funnel. Otherwise, if the drain valve operates flooding the room, the boiler manufacturer shall not be deemed responsible.

We recommend filling the system at a pressure of 1.0 - 1.2 bar (pressure is shown with the b symbol on the boiler display) the boiler can still function from 0.6 bar to 2.5 bar.

In case of installation in spaces where temperature may drop below 0°C, inserting appropriate antifreeze in the system is required since the boiler does not have an automatic antifreeze system.

Thermostoves and boilers with domestic hot water production

If the water hardness of your home is high, **we recommend installing a softening system and a filter upstream.**

We recommend having the exchanger undergo yearly maintenance to remove limestone sediments and mineral salts.

5.5 Boiler hydraulic diagram

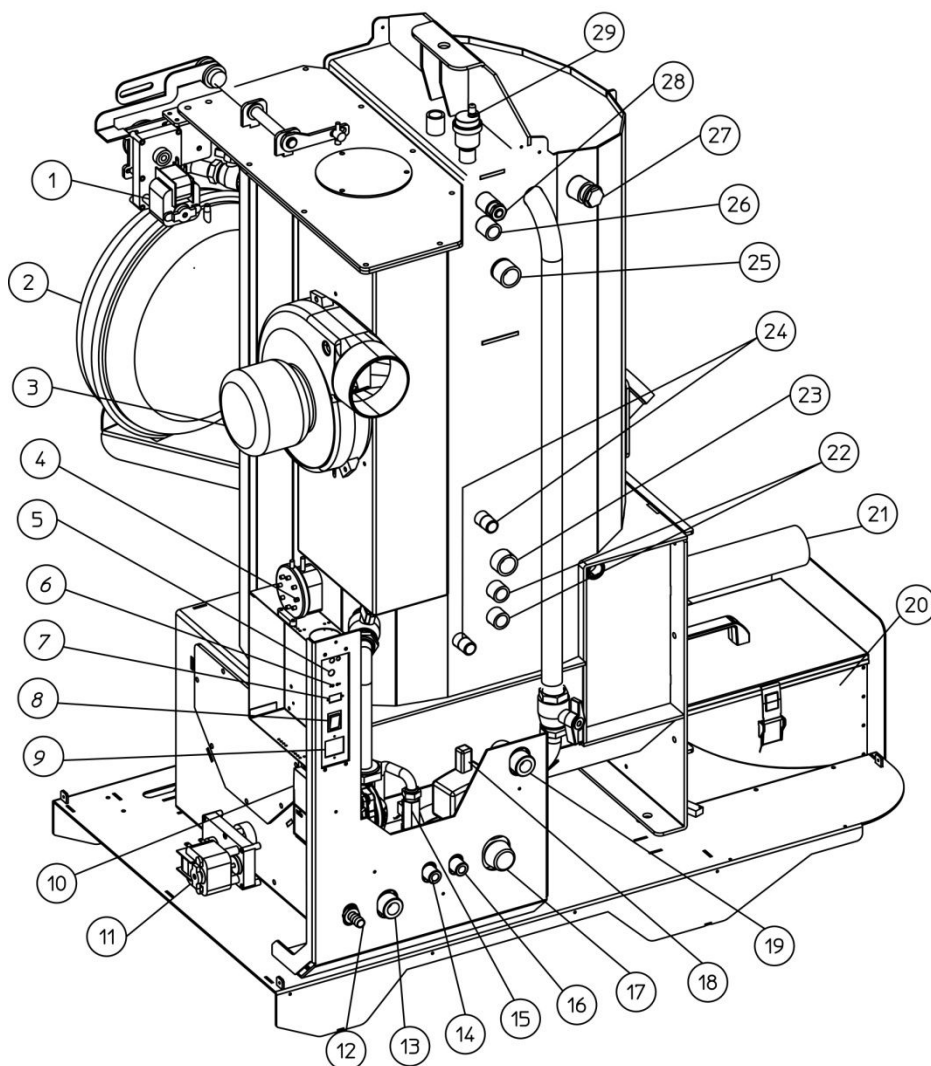

1	TURBULATORS CLEANING GEAR MOTOR	9	POWER SUPPLY OUTLET	17	MIXING VALVE	25	AUXILIARY OUTFEED
2	EXPANSION VESSEL	10	CIRCULATION PUMP	18	3-WAY VALVE	26	THERMOSAFETY
3	FLUE GAS MOTOR	11	BRAZIER CLEANING GEAR MOTOR	19	SYSTEM DELIVERY	27	MAGNESIUM ANODE
4	VACUUM THERMOSTAT	12	VENT SAFETY	20	ASH COMPACTOR	28	PROBE WELL
5	MANUAL RESET	13	SYSTEM RETURN	21	PRIMARY AIR INLET	29	JOLLY VALVE
6	EXTERNAL SENSOR CLAMP	14	DOMESTIC HOT WATER INLET	22	AUXILIARY WELLS		
7	SERIAL PORT	15	FLOW SWITCH	23	AUXILIARY INFEED		
8	MAIN SWITCH	16	DOMESTIC HOT WATER OUTLET	24	SOLAR PANEL CONNECTION		

5.5.1 Approximate hydraulic diagram

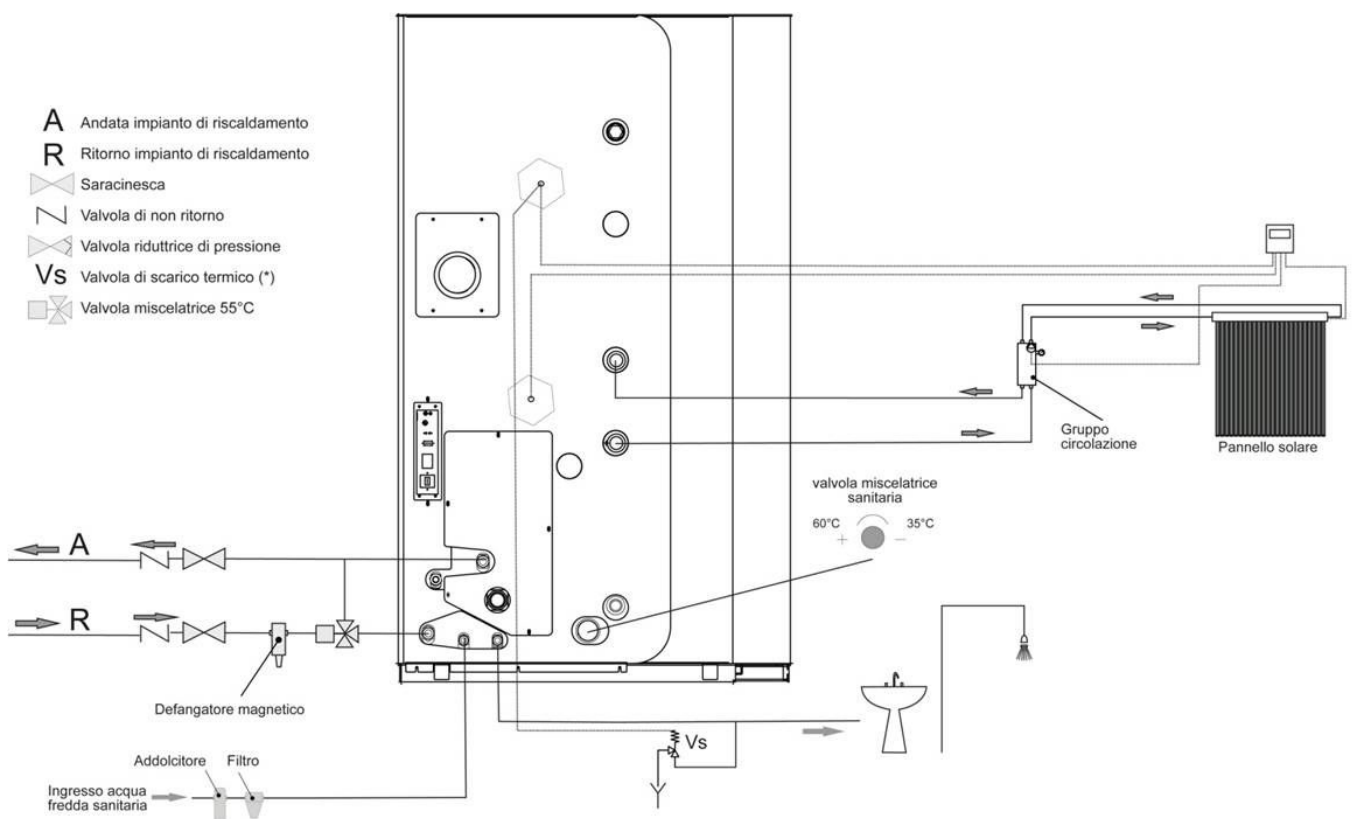
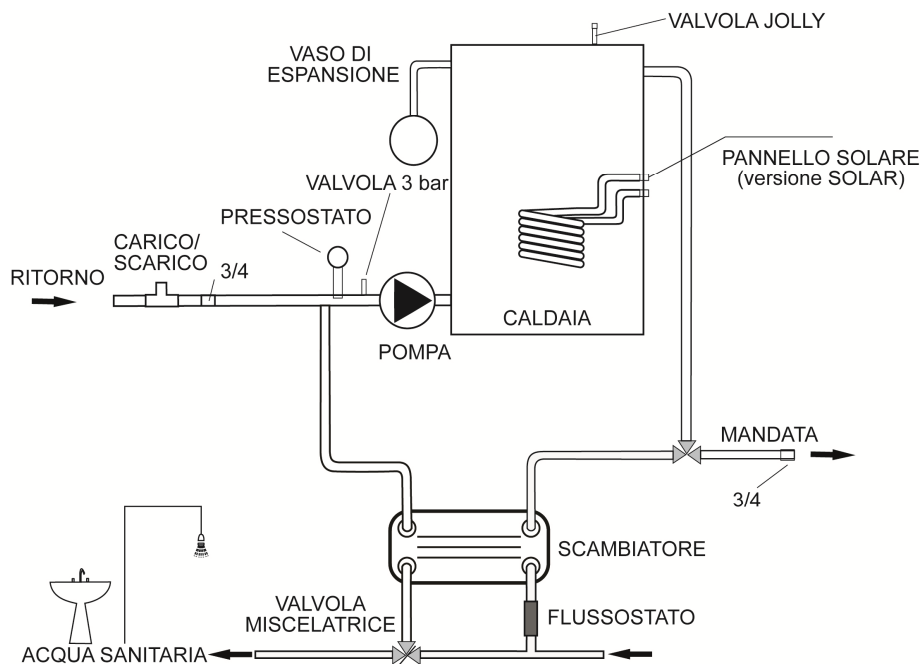

(*) Valvola di scarico termico necessaria solo per i modelli SOLA

Caution: to prevent the heating system from having to be regularly cleaned it is best to **install a magnetic sludge remover**, this filter aids routine maintenance, increases boiler life span, aid removal of impurities and increased global efficiency of the system.

The magnetic sludge remover **filters the heating system** removing sludge, ferrous or sandy residues which circulate in the pipes, if not removed they create surfaces which do not permit heat transmission, consequent pellet consumption and possible boiler malfunction.

6 USE

The **Termoboiler** line boilers are designed to operate 24/7 365 days a year. The boiler has been designed to maintain the water it contains above 70°C. This way, water will always be available for the domestic environment heat request or for the production of DHW. This does not involve continuous pellet consumption, as the boilers are adjusted automatically according to the heat requests of the connected utility.

Therefore, to guarantee proper operation, work parameters and configurations must be set correctly.

Below the essential points to be set correctly:

- **The heat requirement from the domestic heating system must occur via closing the external thermostat contact and must therefore be connected to an external contact** for example coming from a commercial timed thermostat located inside the house. (see *paragraph 6.3.6*).
- **The boiler power level must be set to 5 and water temperature must be set to 70°C.** (see *paragraph 6.3.3*).

With these settings, the operation periods will be controlled directly from the programmable thermostat inside the house, whilst the production of DHW will be guaranteed automatically by the boiler within 24 hours.

Even if available, we do not recommend activating the activation and deactivation programming, leaving the programmable thermostat to control boiler deactivation (stand-by mode).

All local regulations, including those relating to national and European regulations, must be observed when installing the unit.

Improper installation or use of the device can result in forfeiture of the warranty.

Do not use the unit as an incinerator or in any other way other than that for which it was designed.

No other fuel besides wood pellets must be used.

Do not use liquid fuels.

Do not make any unauthorised modifications to the device.

Only use original replacement parts recommended by the manufacturer.

In general

- Make sure that the room where the boiler is to be installed offers sufficient ventilation (see section "1.3 External air intake vent").
- Make sure that all exhaust system joints are hermetically sealed with silicone (not cemented), are resistant to heat (250 °C) and are not damaged.
- Periodically check (or have someone check) the cleanliness of exhaust fumes.
- **CAUTION: keep all flammable products well away from the boiler when it is operating (MINIMUM: 100 cm from the front wall).**
- **CAUTION: to prevent the escape of fumes, the combustion chamber must be kept closed except during cleaning operations, to be carried out with the stove off.**
- **CAUTION: removing the safety guard inside the tank is strictly prohibited.**
- **CAUTION: in the event of pellet supply while the stove is on, make sure that pellets are not finished and that the flame remains present in the brazier. Also avoid the fuel sack from coming into contact with hot surfaces.**
- **CAUTION: remove any residue of unburned pellets caused by failed ignitions before you start the stove again.**

- **CAUTION:** if during the ignition phase, the boiler does not start and you notice a lot of smoke in the combustion chamber, immediately turn off the boiler and replace pellets in use, as these may be too high in moisture. Forcing ignition could make your boiler a hazard.
- **CAUTION:** if during cleaning, you find traces of spongy or hard (though not ash) pellets, replace the pellets being used as this residue may come from scraps of low quality sawdust not usable in this type of stove. Forcing ignition can cause a fire or strong production of fumes in the chimney.
- **CAUTION:** monitor proper combustion of the pellets in the brazier. Should you detect accumulations of unburned pellets, **IMMEDIATELY TURN OFF** the boiler and contact the support centre.
- **CAUTION:** pay the utmost attention when children are present to prevent them from standing in front of the stove.







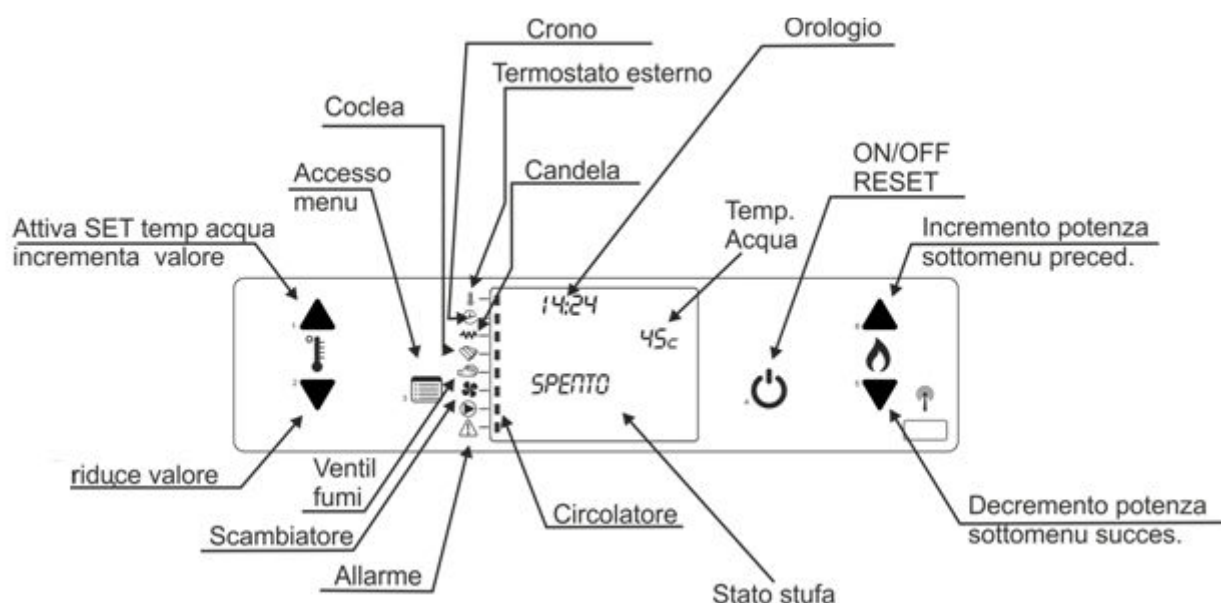

6.1 6.1 Console description

The console displays information about boiler operating status. Access the menu to view various types of displays and adjust the settings available depending on the level of access.







Depending on the operating mode, the displays may have different meanings based on their position on the display.



Below is a list of meanings of LEDs found on control panels:

	Room thermostat LED	The LED is on when it is connected to an external room thermostat and it is closed
	Chrono LED	The LED switches on when the programmable thermostat is activated; meaning, if user parameter 03-01-01 enables chrono, it is different from off
	Igniter plug LED	The LED switches on when the igniter plug is powered.
	Screw feeder on LED	The LED switches on in the time intervals in which the pellet screw feeder is in operation.
	Smoke fan LED	The LED switches on when the smoke fan is on.
	Exchanger LED	The LED switches on when the fan is in operation (air version)
	Pump on LED	The LED switches on when the pump/circulator is in operation (only with Hydro and boiler models)
	Alarms LED	The LED switches on when there is an alarm activated on the boiler

6.1.1 Display functions

4 	BUTTON 4 ON/OFF	Functions: <ul style="list-style-type: none"> • Manual boiler start-up and shut-down • Exit from a sub-menu • Exit from shut-down or alarm (and passage to off status)
5 	BUTTON 5 POWER REDUCTION	Functions: <ul style="list-style-type: none"> • Reduction in set power value • Switching from a sub-menu to the previous one
6 	BUTTON 6 POWER INCREASE	Functions: <ul style="list-style-type: none"> • Increase in set power value • Switching from a sub-menu to the next one
3 	BUTTON 3 MENU SELECTION	Functions: <ul style="list-style-type: none"> • Switching to sub-menus • Switching to programmable thermostat and clock programming • Switching to technical parameters programming.
1 	BUTTON 1 PARAMETER ADJUSTMENT (INCREASE)	Functions: <ul style="list-style-type: none"> • Switching to boiler water temperature setting mode • In temperature setting mode, it increases the set value • In technical parameter setting mode, it increases the set value • In work mode, it activates water setting in the boiler
2 	BUTTON 2 PARAMETER ADJUSTMENT (DECREASE)	Functions: <ul style="list-style-type: none"> • In temperature setting mode, it reduces the set value. • In technical parameter setting mode, it reduces the set value.

6.2 First ignition

Before igniting the boiler, you must have a qualified technician perform "FIRST START-UP" and calibration. For this purpose, we advise you to contact personnel part of our network of authorised support centres.

The company assumes no responsibility for malfunctions due to improper installation, failure to install, incorrect first ignition, or improper use.

Make sure that electrical and plumbing connections have been performed properly. Also check that the hydraulic system has a sufficient expansion tank for maximum safety. Please note that expansion is calculated considering 10% of the whole volume contained in the system. Any damage to the system or to equipment will not be considered under warranty. The presence of the tank fitted on the unit does not guarantee adequate protection against sustained thermal expansion of the system water.

Fill up the system through a refill valve (to be provided externally to the boiler). During recovery, it is advisable not to exceed a maximum pressure of 1 bar. The pressure may be read directly on the display.

The water loading phase should be simultaneous to air exhaust.

Before turning on the boiler, also check that the brazier is positioned correctly inside the combustion chamber.

The first few start-ups, it may give off odours due to the evaporation of paint or grease. Simply ventilate the room to make the odour go away, avoiding prolonged exposure as vapours can be harmful to people or animals. Do not allow children to stay in the room during this first phase.

When the tank is loaded for the first time, the feed screw must fill up for a given period. During this time, pellets will not be distributed within the combustion chamber. To overcome this difficulty, use the command "initial load" in menu 7 of the control panel (*see further details below*).

6.3 Ignition and normal operation

Before igniting the boiler:

- **Check that the furnace door is locked.**
- Make sure that the pellet tank is full or contains enough pellet so that the boiler shall function for the desired amount of time.
- **Make sure that the brazier is clean**, free of ashes, combustion residue or unburned pellets. If necessary, remove the brazier and thoroughly clean it, then replace it with care in its housing).
- In the event of start-up with the programmable thermostat, make sure that the brazier is in the indicated conditions after last use.

When the boiler is connected to the electrical system but not in work mode, the display will show the message "OFF"

6.3.1 Boiler start-up

To start the boiler, press and hold the start button (4) for 2 seconds.

If you start the boiler during the final cleaning phase, the display may show the message "WAIT COOLING." In this case, wait a minute before retrying ignition.

First phase. Preparation

The message "START" will appear on the display. In this phase, which lasts for about one minute, the pellet glow plug activates and combustion chamber forced ventilation starts along with activation of the fume extraction fan.

Second phase. Ignition

After the preparation phase, the display will show the message "LOAD PELLETS" and ignition will begin. This second phase is divided into two parts: pre-loading and actual ignition. First, the pellet feed screw is activated (the Feed screw ON LED  lights up) for a variable time interval, depending on the model, and pellets begin to fall inside the brazier.

Remember that the brazier must be perfectly clean at this beginning of this stage.

Once this pre-loading is completed, the pellet feed screw will stop for a variable amount of time depending on the model (for two to three minutes). After this waiting phase, the pellet feed screw will start to switch on at regular intervals and pellets will then continue falling inside the boiler brazier, while the glow plug and then fume exhaust fan will both remain activated.

As soon as the pellet covers the ignition glow plug hole you will initially notice the brazier redden and then a small flame ignite.

If the pellet continues to fill the brazier without this happening, you can manually interrupt the ignition process without waiting for the "AL 5 NO IGNIT" alarm to affect the boiler.

This second stage is completed when the boiler detects successful ignition of the combustion process, or rather after 4-5 minutes from the ignition of the first flame.

If combustion is not detected within a certain amount of time the no ignition alarm is triggered (message "AT 5 NO IGNIT").

Third phase. Stabilisation

Once combustion triggering has been detected, the third phase will start and the display will show the message "FIRE PRESENT". Pellet feeding is reduced and ventilation increased in order to allow a stabilisation of the flame and disposal of excess pellets accumulated in the brazier during the ignition phase. This phase lasts about 5 minutes.

Once the stabilisation phase has been completed ("FIRE PRESENT"), the boiler passes to the normal working phase.

6.3.2 No start-up

As stated if the combustion trigger is not detected a no ignition alarm is signalled, the display will show the message "AT 5 NO START" and an acoustic signal will be heard at regular intervals (if the buzzer function is active in Menu 6).

To disable the alarm, hold and press the ON-OFF (4) (about 2 seconds). The acoustic alarm will stop and the boiler will first return to "FINAL CLEANING" status and then to "OFF."

Before starting a new ignition cycle verifying the cause of the alarm is required, specifically:

- **Check that the pellet tank is not empty.**
- **Check that the brazier is in the right position.**

Before attempting a new combustion remove the non-combusted pellet from the brazier.

CAUTION: An excessive quantity of pellets in the brazier, a humid pellet or dirty brazier make the ignition stage difficult. If these critical conditions are present a dense white smoke capable of causing an explosion in the combustion chamber may form. The explosion can be of such intensity as to break the glass of the fire door. Therefore pay attention to never stay in front of the boiler during ignition stage if the fuel releases a dense smoke.

The boiler is however equipped with all safety systems required to minimise this risk.

If the device does not turn on regularly, the main cause may be insufficient maintenance or poor pellet quality.

6.3.3 Normal Operation

As soon as the ignition phase is over, the boiler will go into normal working mode.

During this phase, the display will show the following information:

- The first line shows the time.
- On the second line to the right the temperature of the water in the boiler appears.
- The third line shows the message "WORKING" with the set power (from 1 to 5) to the side.
- The fourth line usually shows the instantaneous working power (flashing from 1 to 5). The message "MODULATE" also is shown when water temperature reaches the set temperature (see corresponding paragraph).

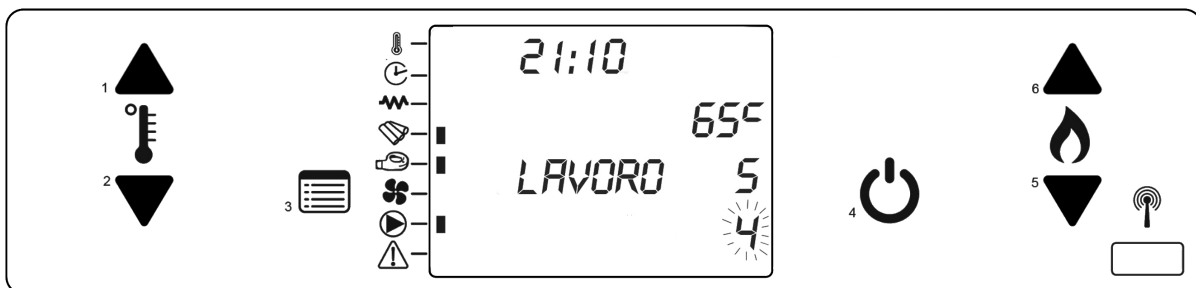

During normal working mode, the following operations can be performed:

- **Set Boiler power** choosing from one of the 5 available levels. Power setting is carried out via BUTTONS "6" (to increase) and "5" (to decrease).
- **Set thermostat parameters** (see corresponding section).
- Set the required boiler temperature between an interval from 60°C to 80°C. **The optimal temperature for our boiler is 70°C**, we sincerely recommend leaving this setting except for justified technical reasons.
Press "1" once and then set the temperature with button "1" to increase and "2" to decrease.
- **Display the water circuit pressure.** Accessing menu 1.

Periodic brazier cleaning is also active during working mode. Brazier cleaning mode is activated at regular intervals of about one hour. In this way, the smoke extractor works at maximum power while pellet feeding is reduced to minimum. For boilers with automatic cleaning of the flue gas pass and/or of the brazier, also these functions are activated.

This operation is necessary for eliminating ash deposits inside the brazier and for ensuring proper aeration and combustion. During brazier cleaning, the display will show the message "BRAZIER CLEANING".

If you notice excessive accumulation of pellets in the brazier during normal operation, turn off the boiler immediately and contact a support centre.

6.3.4 Modulation based on boiler water temperature

The boiler is equipped with boiler water temperature sensor that allows it to modulate its power according to the desired temperature.

To set water temperature, press button "1". Press button "1" once and the bottom of the display will show the message " SET WATER TEMP", while the upper part of the display will show the set water temperature. To modify this value, use buttons "1" and "2" until you reach desired temperature (60°C to 80°C). **We recommend setting water temperature in the boiler at 70° C.**

Briefly press button "4" to exit the programming or wait a few seconds to automatically return to the work or stand-by position.

During the working phase, if the water temperature in the boiler is much lower than the set value, the boiler operates at the maximum power level set.

However, when the boiler water temperature approaches the set value (difference of less than 4° C), the boiler gradually decrements the power level. The last line of the display shows a flashing number that indicates the power level at which the boiler is working at that moment. The more the water temperature decreases the more the power level increases until it returns to the maximum power value set initially. **We recommend always setting the boiler power to its maximum value "5".**

If, despite reducing power, boiler water temperature continues to rise and reaches the set temperature, the bottom line of the display will show "MODULATE". If the water temperature tends to rise further exceeding the set temperature by 8 °C the boiler goes in standby mode. The display will show "WAITING FOR COOL.", during the final cleaning phase, and then "ECO STOP", during the standby mode.

6.3.5 Circulator

This model has a circulator for direct connection of the system boiler to radiators. The circulator starts as soon if the water in the boiler exceeds a temperature of 60° C (optimal value for this model) and above this temperature it operates according to the temperature requested by the external environment thermostat.

6.3.6 External thermostat

Boiler operation must be adjusted by an external room thermostat connected to the electronic board (see wiring diagram). The thermostat connection is performed with a 2x0.5 mm² cable. The contact to be used is NO (Normally open). **This operation should be performed by qualified personnel.**

A terminal board is found on the rear of the boiler to allow you make the desired connection (see *picture 14*).

You may insert in parallel more than one external contact (e.g. the contacts relative to two different zone valves.)

If at least one external thermostat is active (contact closed), the boiler pump starts working, powering the heating system and the temperature inside the boiler will start dropping until reaching the **70°C** set restart threshold. When this threshold is reached, the boiler will light automatically in order to deal with the system power request.

Once the system is satisfied, the external thermostat opens again and the pump will stop immediately and as soon as the boiler temperature exceeds the threshold of **70°C**; the boiler will modulate and will keep modulating until it reaches **78°C**, where the stand-by function will intervene, shutting down the boiler.

6.3.7 Domestic hot water production

The Termoboiler line boilers feature incorporated domestic hot water production. By using the 100 litres hot water storage tank with which they are equipped.

The DHW is produced by means of a plate exchanger, connected to a flowswitch upstream to control the boiler and to a mixing valve downstream to adjust the DHW outlet temperature between 35°C and 60°C.

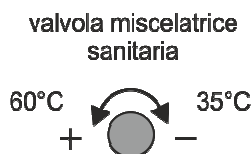

At the back of the boiler the mixing valve knob can be accessed to adjust the temperature of the outgoing hot water (see fig. 14.)

During the normal operating stage if the water temperature is less than 72°C (value settable from technical parameter) the DHW request brings the boiler to operate at maximum power ("level 5").

If the boiler is in standby mode ("ECO STOP"), the request of DHW has no effect if active for a time less than 120" (value settable from the technical menu) until the boiler temperature is higher than 72 °C. Then the boiler starts automatically.

6.3.8 Brazier cleaning

During normal operation in work mode, "BRAZIER CLEANING" is activated at set intervals. During this time, the display will show the message "BRAZIER CLEANING", boiler ventilation increases and the flame lowers in the brazier and in the MATIC models, with automatic cleaning, turbulator cleaning is enabled. This operation is necessary to decrease the likelihood of ash accumulation inside the brazier and flue gas pass, maintaining efficiency overtime.

If you notice an excessive accumulation of pellets or ash in the brazier (over half the level of the brazier itself) or excessive accumulation of ash in the brazier turned off, immediately switch off the boiler and clean the brazier. Promptly contact a support centre.

6.3.9 Shutdown

Termoboiler line boilers are been designed to run 24/7. However, the boiler may be switched off any time by pressing button 4 for a few seconds.

Once the shutdown signal has been received, the display will show the "FINAL CLEANING" message and the fume exhaust fan will continue to run at full speed for a minimum time of about 10 minutes to ensure complete cooling of the boiler. Additionally, as for the brazier cleaning, the mechanical cleaning of the flue gas pass and brazier is activated (in the models where provided.)

CAUTION: Never disconnect the power supply at this stage, as this may create problems for the boiler and compromise the subsequent phases of ignition.

6.3.10 Interruption of power supply

In the event of a brief interruption in the power supply (under 10 seconds), the stove will automatically re-start without any alarms.

If power is lost for a longer time and the boiler was in work mode, the standby mode is activated and the boiler will start automatically. If lack of power occurs during the ignition phase, an "AL 1 - BLACK OUT" alarm will be generated. The boiler will therefore not start back up automatically, but first the alarm will need to be manually removed.

6.3.11 Remote control

The boiler control panel has been designed to receive all functions even via supplied remote control. (CR2025 3V type battery)

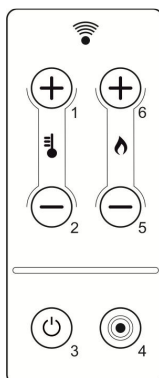

BUTTON 1	<ul style="list-style-type: none"> • Switching to boiler water temperature setting mode • In temperature setting mode, it increases the set value • In technical parameter setting mode, it increases the set value • In work mode, it activates water setting in the boiler
BUTTON 2	<ul style="list-style-type: none"> • Switching to room temperature setting mode • In temperature setting mode, it reduces the set value. • In technical parameter setting mode, it reduces the set value. • In work mode, it activates room temperature setting
BUTTON 3	<ul style="list-style-type: none"> • Switching to sub-menus • Switching to programmable thermostat and clock programming • Switching to technical parameters programming.
BUTTON 4	<ul style="list-style-type: none"> • Manual boiler start-up and shut-down • Exit from a sub-menu • Exit from shut-down or alarm (and passage to off status)
BUTTON 5	<ul style="list-style-type: none"> • Reduction in set power value • Switching from a sub-menu to the previous one
BUTTON 6	<ul style="list-style-type: none"> • Increase in set power value • Switching from a sub-menu to the next one

7 THE MENU

Pressing the button "3" grants access to the menu. It is divided into different items and levels that allow you to access board settings and programming. Menu items that allow you to access technical programming are protected by an access key.

User menu

The following table briefly describes the structure of the menu, focusing only on selections available to the user in this section.

To operate from the menu, follow the guidelines below:

- The "3" key grants access to the menu or submenu selected
- Use button "4" to do the reverse and exit the menu or sub-menu in which you are located
- Use buttons "1" and "2" to modify a parameter value (temperature, time, etc.)
- Use buttons "5" and "6" to move horizontally between different menus or sub-menus or different parameters.

7.1 MENU 01 "WATER PRESSURE"

Menu 1 shows the boiler water pressure. Use buttons "1" and "2" to disable the pressure control ("off") in the event the boiler is connected to an open vessel or the pressure transducer fails.

7.2 MENU 02 "CLOCK SET"

You can set the current time and date in this menu. The board is equipped with a lithium battery that allows internal clock autonomy over 3/5 years.

Enter the MENU and set, in order:



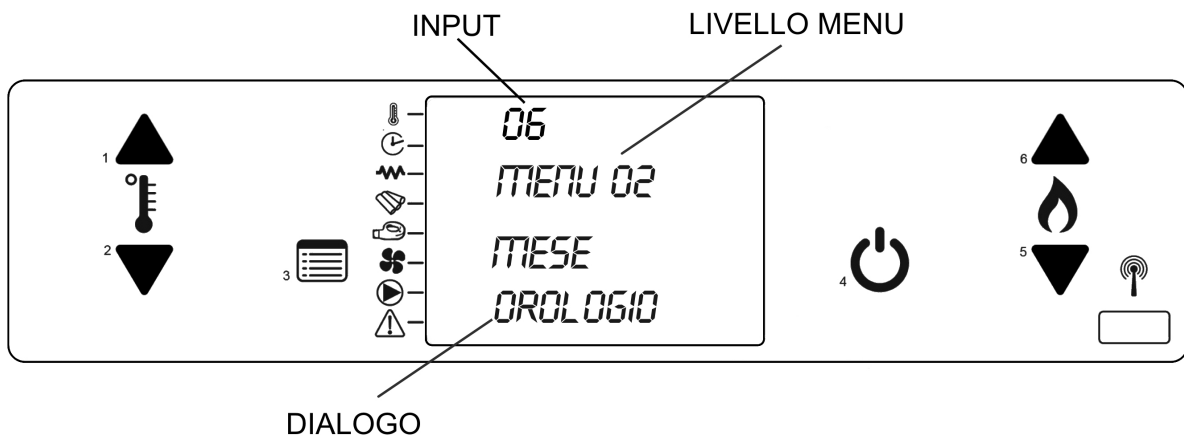



01	The day of the week	(Monday ... Sunday)
02	The time	(0..23)
03	The minutes	(0..59)
04	The day of the month	(1..31)
05	The month of the year	(1..12)
06	The current year	(2000.. 2099)



7.3 MENU 03 "CHRONO SET"

Use this menu to enable and programme start-ups and shutdowns. There are eight different possibilities divided into three groups:

- **Daily programme:** 2 start-ups and shutdowns valid each day.
- **Weekly programme:** 4 start-ups and shutdowns, for which you can decide which days of the week they must be active.
- **Weekend program:** 2 start-ups and shutdowns valid only for Saturday and Sunday.

Below is the diagram of the various Menu levels. Access the menu by pressing "3" , return to the previous menu by pressing "4" , scroll through the menu by pressing "5" and "6"   and change the value by using keys "1" and "2"  .

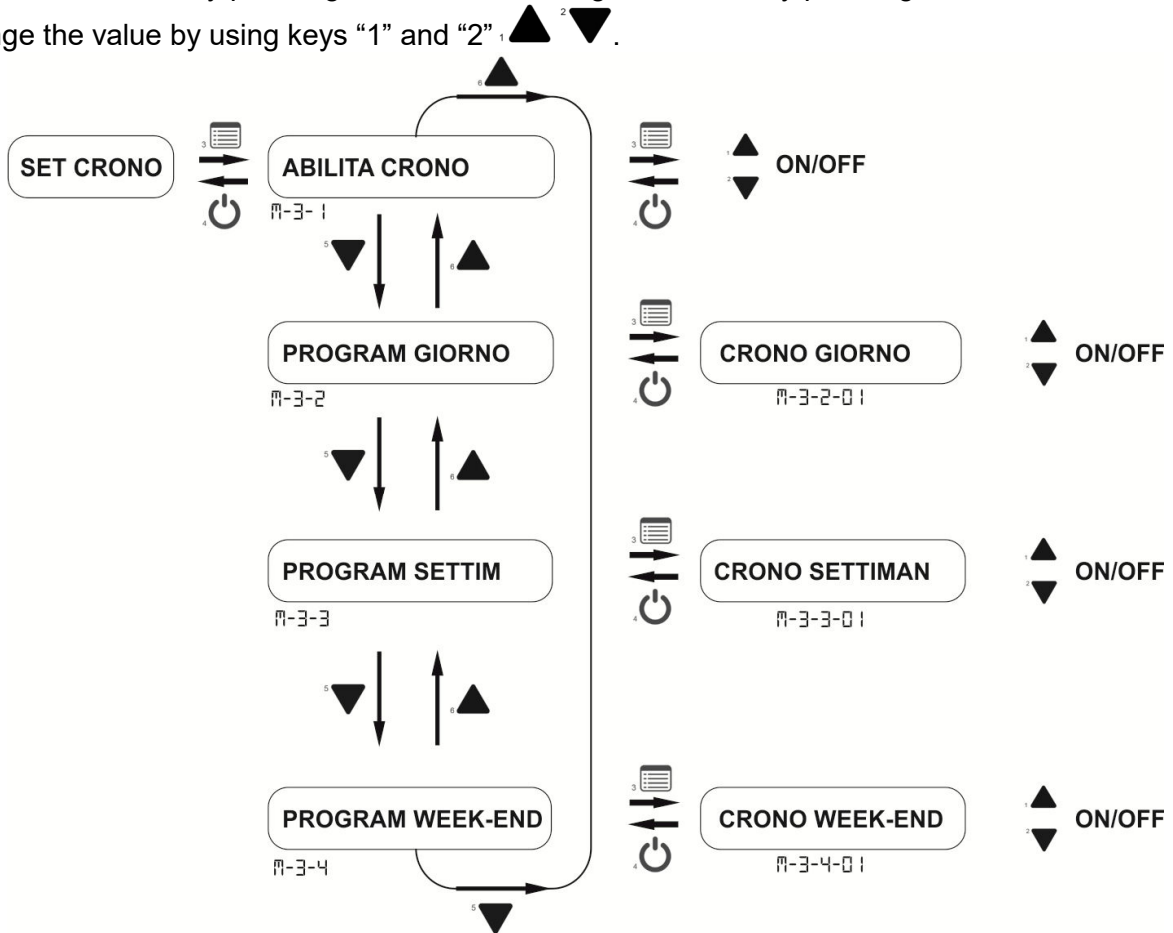

7.3.1 Menu 3-1 "ENABLE CHRONO"

Allows you to enable and disable all programmable thermostat functions. If the value is "off", all set programmes are disabled.

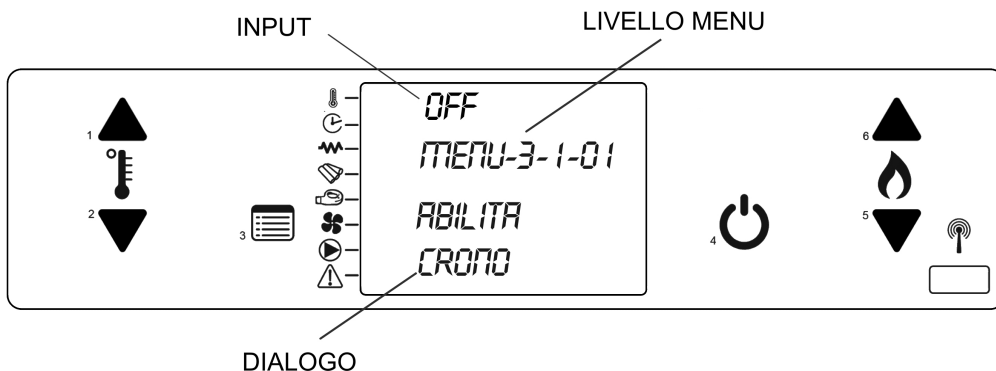

7.3.2 Menu 3-2 “DAILY PROGRAMME”

Allows you to enable, disable and set all daily programmable thermostat functions.

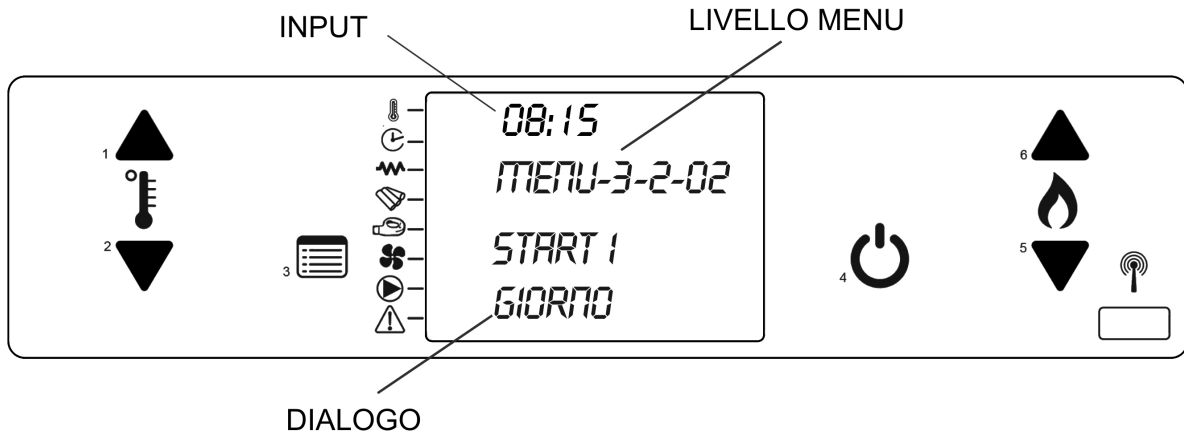

After having putting the first parameter (M-3-2-01) “DAILY CHRONO” to "on", you can set two start-ups and two shutdowns. For each parameter, you can set the startup or shutdown time or the value "off", if you do not wish to activate the daily programming.

Menu level	Selection	Meaning	Possible values
M 3-2-02	START 1	Activation time	00:00-23:50 -OFF
M 3-2-03	STOP 1	Deactivation time	00:00-23:50 -OFF
M 3-2-04	START 2	Activation time	00:00-23:50 -OFF
M 3-2-05	STOP 2	Deactivation time	00:00-23:50 -OFF

7.3.3 7.3.3 Menu 3-3 “WEEKLY PROG-”

The weekly programming group includes 4 start-ups and 4 shutdowns For each on-off pair, you can decide which day of the week to activate the corresponding pair controls.

The first parameter, M-3-3-01 “WEEKLY CHRONO”, allows you to enable or disable all weekly programmable thermostat settings.

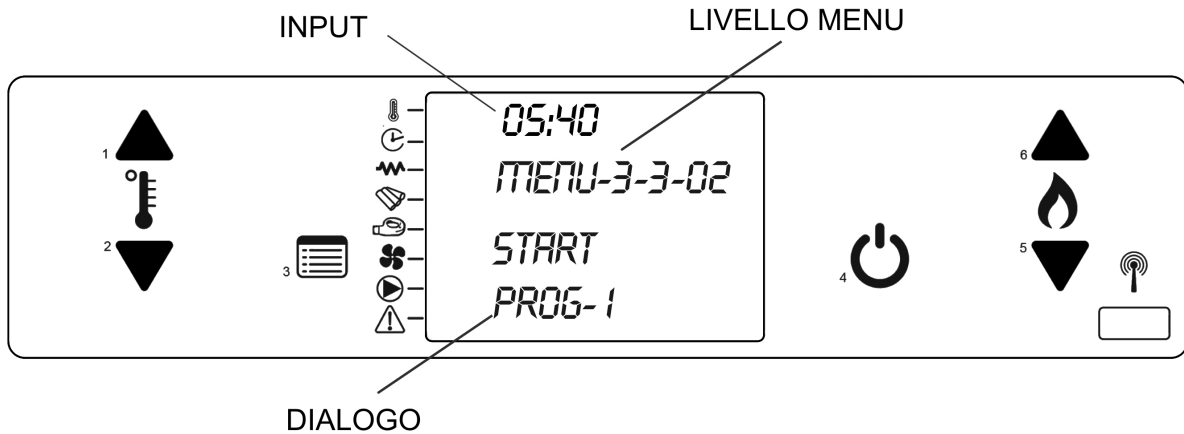

After having set the first parameter (M-3-3-01) “WEEKLY CHRONO” to "On", you can set 4 start-ups and 4 shutdowns. For each parameter, you can set the startup or shutdown time or the value "Off", if you do not wish to activate the programming. After each pair of startup and shutdown times there are 7 parameters corresponding to the 7 days of the week. Each of these parameters can be set to "on" or "off" based on which programming you wish to activate corresponding to that day of the week. (See following tables).

PROGRAMME 1			
<i>Menu level</i>	<i>Selection</i>	<i>Meaning</i>	<i>Possible values</i>
⌘ 3-3-02	START PROG 1	on time	00:00-23:50 -OFF
⌘ 3-3-03	STOP PROG 1	off time	00:00-23:50 -OFF
⌘ 3-3-04	MONDAY PROG 1	reference day	on/off
⌘ 3-3-05	TUESDAY PROG 1		on/off
⌘ 3-3-06	WEDNES-PROG 1		on/off
⌘ 3-3-07	THURSDAY PROG 1		on/off
⌘ 3-3-08	FRIDAY PROG 1		on/off
⌘ 3-3-09	SATURDAY PROG 1		on/off
⌘ 3-3-10	SUNDAY PROG 1		on/off

PROGRAMME 2			
<i>Menu level</i>	<i>Selection</i>	<i>Meaning</i>	<i>Possible values</i>
⌘ 3-3-11	START PROG 2	on time	00:00-23:50 -OFF
⌘ 3-3-12	STOP PROG 2	off time	00:00-23:50 -OFF
⌘ 3-3-13	MONDAY PROG 2	reference day	on/off
⌘ 3-3-14	TUESDAY PROG 2		on/off
⌘ 3-3-15	WEDNES-PROG 2		on/off
⌘ 3-3-16	THURSDAY PROG 2		on/off
⌘ 3-3-17	FRIDAY PROG 2		on/off
⌘ 3-3-18	SATURDAY PROG 2		on/off
⌘ 3-3-19	SUNDAY PROG 2		on/off

PROGRAMME 3			
<i>Menu level</i>	<i>Selection</i>	<i>Meaning</i>	<i>Possible values</i>
⌘ 3-3-20	START PROG 3	on time	00:00-23:50 -OFF
⌘ 3-3-21	STOP PROG 3	off time	00:00-23:50 -OFF
⌘ 3-3-22	MONDAY PROG 3	reference day	on/off
⌘ 3-3-23	TUESDAY PROG 3		on/off
⌘ 3-3-24	WEDNES- PROG 3		on/off
⌘ 3-3-25	THURSDAY PROG 3		on/off
⌘ 3-3-26	FRIDAY PROG 3		on/off
⌘ 3-3-27	SATURDAY PROG 3		on/off
⌘ 3-3-28	SUNDAY PROG 3		on/off

PROGRAMME 4			
Menu level	Selection	Meaning	Possible values
⌘ 3-3-29	START PROG 4	on time	00:00-23:50 -OFF
⌘ 3-3-30	STOP PROG 4	off time	00:00-23:50 -OFF
⌘ 3-3-31	MONDAY PROG 4	reference day	on/off
⌘ 3-3-32	TUESDAY PROG 4		on/off
⌘ 3-3-33	WEDNES- PROG 4		on/off
⌘ 3-3-34	THURSDAY PROG 4		on/off
⌘ 3-3-35	FRIDAY PROG 4		on/off
⌘ 3-3-36	SATURDAY PROG 4		on/off
⌘ 3-3-37	SUNDAY PROG 4		on/off

7.3.4 Menu 3-4 "WEEKEND PROGRAM"

Allows you to enable, disable and set programmable thermostat functions for the weekend (Saturday and Sunday). As per daily programmes, we have an enabling parameter and 2 pairs of start-up and shutdown times. Programming will be active as stated only on Saturday and Sunday.

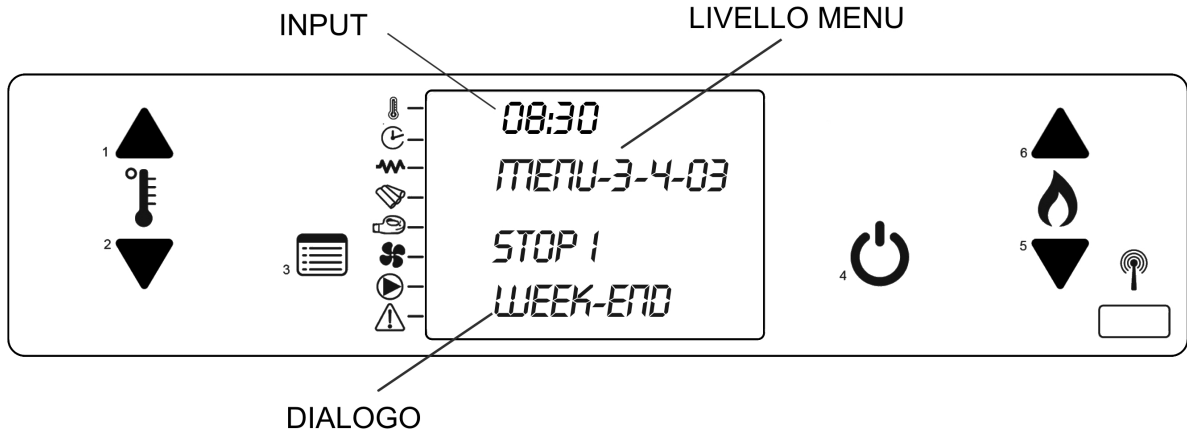

TIP: to avoid confusion and unwanted start-up and shutdown, activate only one programme at a time if you do not know exactly what your desired programming is. Disable the daily programme if you want to use weekly programming. Always disable the weekend programme if you are using weekly programmes 1,2,3 and 4.

Activate the weekend programme only after having disabled weekly programming.

7.4 Menu 04 "CHOOSE LANGUAGE"

Allows you to select the dialogue language among those available.

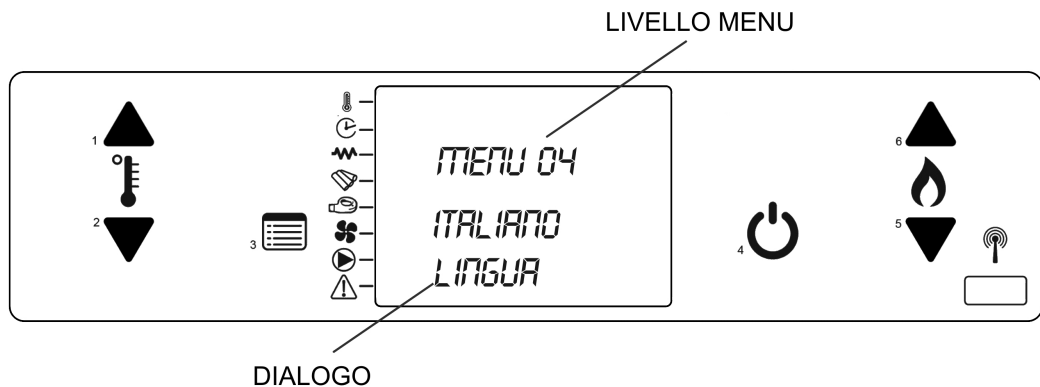

7.5 Menu 06 "BUZZER MODE"

When "off," acoustic signal is disabled in the event of an alarm. When "on," sets off a buzzer when an alarm is activated.

7.6 Menu 07 "INITIAL LOAD"

When the display shows the message "OFF," allows you to preload pellets for a time equal to 90". Press the "1" key to start and "4" key to stop. Once preloading is completed, remove the loaded pellets from the brazier.

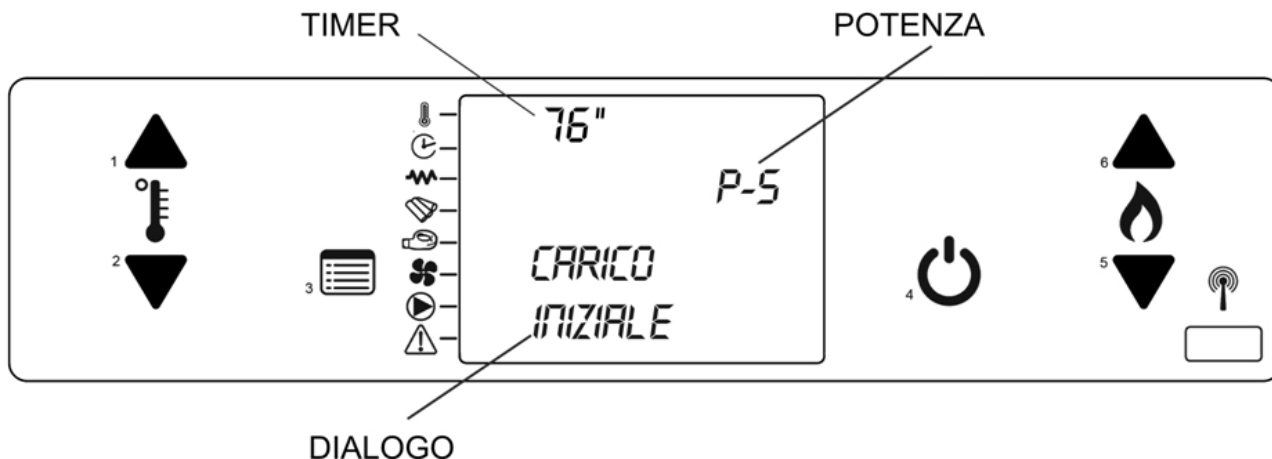

7.7 Menu 08 "BOILER STATUS"

The boiler status menu shows the current state of the boiler, showing some sensor values and other variables inside the boiler. Four pages displayed in succession are available. This menu is for qualified service personnel use.

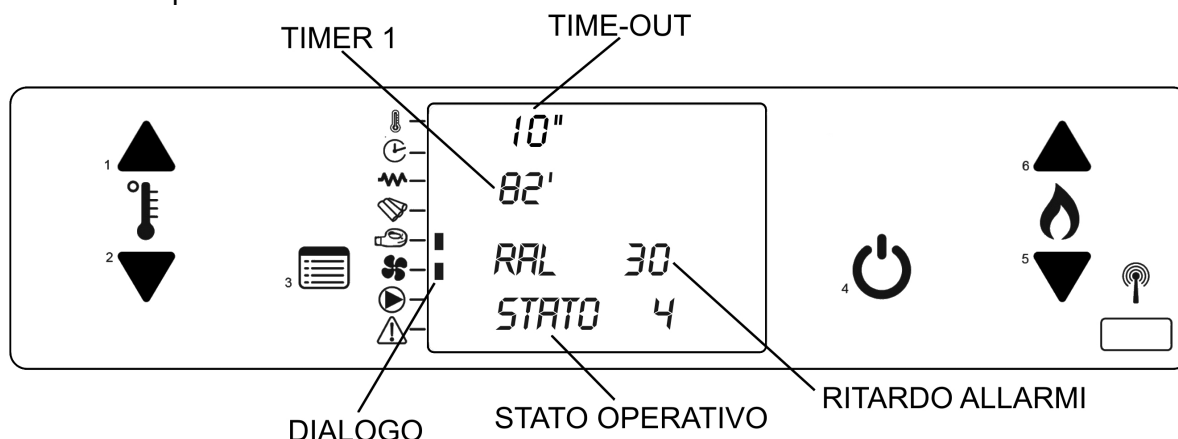

7.8 Menu 09 "TECHNICAL CALIBRATIONS"

This menu is protected by an access key and is intended for qualified service personnel.

7.9 Menu 10 "PELLET TYPE"

This menu allows you to simultaneously increase or decrease all pellet lowering parameters (quantity of pellets and brazier loading).

The set default value is 00. Press keys (1) and (2) to modify said value from -9 to +9.

For each unit, pellet load times are increased or decreased by 2.5 %.

7.10 Menu 11 "FIREPLACE TYPE"

This menu allows users to simultaneously increase or decrease all smoke fan parameters (draft).

The set default value is 00. Press keys (1) and (2) to modify said value from -9 to +9.

For each unit, smoke motor revs are increased or decreased by 2.5%.

8 SAFETY AND ALARMS

8.1 Safety devices

CAUTION: During operation, some parts of the boiler (door, handle, ceramic parts) may reach very high temperatures, therefore be extremely careful, use caution, and always follow the instructions.

If during operations any part of the boiler or the exhaust pipe leaks smoke, immediately turn off the boiler without removing the power supply and ventilate the room. Then, once cooled down, check the reason for the leak and, if necessary, call the specialised technical personnel.

The boiler is equipped with several devices which intervene in order to ensure safe operation.

CAUTION: Safety devices are designed to eliminate any risk of damage to persons, animals or things, and tampering with them or having unauthorised personnel operate may compromise their safety.

Safety devices on the boiler are the following:

8.1.1 Fume exhaust pressure sensor

This sensor is connected to the fume exhaust pressure duct. It controls the negative pressure inside the boiler, monitoring any clogging of the chimney flue, the opening of the combustion chamber door, and the block of the pellet duct allowing a safe use of the boiler.

When it activates

As already said, the causes that may trigger this alarm are multiple. Below the main ones:

- If, in the fumes exhaust duct the conditions of correct operation are changed (improper installation, the presence of obstacles or impediments in the exhaust tube, negligent maintenance, adverse weather conditions such as persistent wind, etc.).
- If the boiler flue gas pass contains an accumulation of ash that obstructs the normal passage of the combustion fumes (poor or negligent maintenance, low quality pellet, improper combustion, etc.).
- If the boiler has combustion parameters not adjusted correctly (in particular, the low power combustion parameters).
- If the combustion chamber door is left open.
- If pellet accumulates inside the brazier supply duct (result of incorrect combustion).

In each of the cases above, the vacuum pressure sensor (vacuum thermostat) stops electrical power supply to the pellet feed screw, thus blocking pellet feeding to the brazier and sending an alarm signal to the board.

When the alarm is triggered, the display shows the message "**AL 8 – NO VACUUM**".

8.1.2 Boiler /structure temperature sensor

The Termoboiler line boilers are equipped with a manual reset bulb thermostat, which prevents the boiler water temperature from exceeding 85°C. It is also equipped with a safety thermostat (klixon) which prevents the structure from reaching excessive temperatures.

When it activates

The bulb thermostat is triggered if the temperature of the water in the boiler exceeds the 85°C threshold while the klixon triggers if the temperature in the pellet duct exceeds the same 85°C threshold. In both situations the thermostat interrupts the electrical power supply to the screw feeder, thereby blocking the pellet supply to the brazier and sending an alarm signal to the board.

The display will show the message

"AL 7 – Thermal safety".

8.1.3 Smoke temperature sensor

The smoke sensor is directly connected to the electronic board and keeps operating temperature of exhaust fumes from the boiler under constant control, allowing safe use of the boiler.

How it works

If fume temperature exceeds the first pre-set temperature limit, the board passes into modulation mode. The display will show the message “**MODULATE / MAX SMOKE**”. At the same time if, despite passage to modulation, the fume temperature continues to increase and exceeds the second pre-set safety limit, the boiler will pass into alarm mode. Pellet flow is interrupted and fume exhaust speed is set to maximum.

The display will show the message **AL 3 – “SMOKE TEMP”**.

The boiler constantly checks operation of the smoke sensor, if the sensor is momentarily and/or accidentally removed from its housing, or the connector is not correctly positioned on the electronic board or the sensor fails for any reason, the fault is signalled via display message **AL 2 – “SMOKE SENSOR”**.

8.1.4 Water temperature sensor

The water sensor is directly connected to the electronic board and keeps operating water temperature in the boiler under constant control, allowing safe use of the boiler.

How it works

If water temperature exceeds the first pre-set temperature limit, the board passes into modulation mode. The display will show the message “modulate”. At the same time if, despite passage to modulation, the water temperature continues to increase and exceeds the second pre-set safety limit (about 90 °C), the boiler will pass into alarm mode.

The display will show the message **AL A – WATER TEMP”**.

The boiler constantly checks water probe operation, if the sensor is momentarily and/or accidentally removed from its housing, or the connector is not correctly positioned on the electronic board or the sensor fails for any reason. The fault is signalled via display message **AL 9 – “WATER SENSOR”**.

8.1.5 Water pressure switch

The water pressure switch is directly connected to the electronic board and keeps operating water temperature in the boiler under constant control, allowing safe use of the boiler.

How it works

If water pressure drops below 0.5 bar or over 2.5 bar, the boiler passes into alarm mode and **AL b – “WATER PRESS”** appears on the display.

8.2 Alarms

When an operating anomaly occurs, the board intervenes to signal the irregularities, operating in different modes depending on the type of alarm. The following alarms can occur:

Cause of alarm	Display message
No power	AL1 BLACK-OUT
Smoke temperature sensor	AL2 SMOKE SENSOR
Smoke overtemperature	AL3 SMOKE TEMP
Smoke fan fault	AL4 EXTRACT FAULT
No start-up	AL5 NO START
Shutdown during work mode	AL6 NO PELLETS
General safety thermostat	AL7 THERMAL SAFETY
Safety pressure switch	AL8 NO VACUUM
No or low water sensor	AL9 WATER SENSOR
Water overtemperature	ALa WATER TEMP
Water press. outside allowed values	ALb WATER PRESS

EACH ALARM CONDITION CAUSES IMMEDIATE BOILER SHUTDOWN

To exit from an alarm condition, always press button "4" until the message "FINAL CLEANING" appears.

You will also need to take additional steps, depending on the type of alarm generated. If you do not exit from the alarm condition within a given time (a few hours), the alarm will be sent into boiler memory and the display will show the message "ALARM MEMORY". To exit from this condition, press button "4" as per above.

AL 1 - Black-out

This alarm is activated when the boiler is disconnected from the mains.

What to do

Put the boiler in stand-by by pressing the off button for a few seconds.

AL 2 - Smoke sensor

This alarm signals breakage of the smoke sensor

What to do

- Put the boiler in stand-by by pressing the off button for a few seconds (4).
- Wait and make sure that the combustion of pellets left in the brazier has been completed.
- If necessary, call a support centre to replace the sensor

AL 3 - Smoke temp

This alarm signals excessive smoke exhaust temperature (see safety devices)

What to do

- Put the boiler in stand-by by pressing the off button for a few seconds (4).
- Wait and make sure that the combustion of pellets left in the brazier has been completed.
- If necessary, call a support centre to replace the sensor

AL 4 - Extract fault

This alarm indicates a failure to read the revs of the smoke expulsion motor by the control board. It may have been activated due to motor fault or due to a lack of connection between the rev reader (encoder) in the motor and the board.

What to do

Put the boiler in stand-by by pressing the off button for a few seconds.

Try switching the boiler back on.

Contact your support centre if the problem persists.

AL 5 – No start

This alarm signals an ignition failure. This alarm is activated when, during the start-up phase, a maximum waiting time (about 20 minutes) is exceeded without the machine switching on successfully. (*see ignition*)

AL 6 – No pellet

This alarm indicates a flame failure in the brazier during normal boiler operation. The main causes are: no pellets in the tank or blocking of the pellet feed screw.

What to do

- Put the boiler in stand-by by pressing the off button for a few seconds.
- Empty the brazier of all unburned accumulated pellets.
- In the event of pellet exhaustion in the tank, refuel the boiler and ignite it again. Do not insert pellets until the boiler has cooled completely. **Pellet refilling must always be performed with the boiler off** or with the boiler operating with the flame present.
- In the case of a pellet feed screw block, empty the tank and remove any foreign bodies present in the feed screw. Then refill with pellets and start the boiler back up
- **In the case of repeated feed screw blocks, call a support centre**

AL 7 - Thermal safety

This alarm is activated by intervention of the safety thermostat installed inside the boiler

What to do

- Put the boiler in stand-by by pressing the off button for a few seconds.
- Wait and make sure that the combustion of pellets left in the brazier has been completed.
- **Reset the safety thermostat** located on the rear of the boiler under the outlet (*see fig. 14*).

Before resetting, make sure that the boiler is **off and completely cooled down**, then proceed as follows:

- Unscrew the cap located on the rear of the boiler (*see figure 14*);
- Press the red button applying a slight pressure;
- Re-screw the cap in its housing;
- **After having cleaned the brazier**, re-start the boiler by pressing button 4;

AL 8 - No vacuum

This alarm is activated by intervention of the vacuum sensor (vacuum gauge)

What to do

- Put the boiler in stand-by by pressing the off button for a few seconds.
- Wait and make sure that the combustion of pellets left in the brazier has been completed.
- Wait for the boiler to cool down, then verify and remove the causes that triggered the safety device. Finally, after having cleaned the brazier, re-start the boiler by pressing the ON/OFF button (4).
- **In the event of a repeated alarm, call the support centre.**

AL 9 - Water sensor

This alarm is activated by the breakage or disconnection of the water probe of the boiler.

What to do

- Put the boiler in stand-by by pressing the off button for a few seconds (4).
- Wait and make sure that the combustion of pellets left in the brazier has been completed.
- If necessary, call a support centre to replace the sensor

AL A -Water temp

This alarm is activated by the over-temperature of the water in the boiler.

What to do

- Put the boiler in stand-by by pressing the off button for a few seconds.
- Wait and make sure that the combustion of pellets left in the brazier has been completed.
- Verify and remove the causes which caused the safety devices to go off.
- After having cleaned the brazier, re-start the boiler by pressing button (4);

AL b - Water press

This alarm is activated by the incorrect pressure of the water in the boiler.

What to do

- Put the boiler in stand-by by pressing the off button for a few seconds.
- Wait and make sure that the combustion of pellets left in the brazier has been completed.
- Verify and remove the causes which caused the safety devices to go off.
- **Check and fix pressure level in the boiler circuit.**
- After having cleaned the brazier, re-start the boiler by pressing button 4.

9 WARNINGS AND MAINTENANCE

All maintenance operations (cleaning, potential replacements, etc.) must be carried out when the fire is out and the boiler is cold. In addition, do not use any abrasive substances.

CAUTION: FAILURE TO CLEAN AFFECTS SAFETY

9.1 Opening the door

The door must remain closed during operation. The door should be opened only with the boiler off and cooled down to perform maintenance and routine cleaning.

9.2 Disposal of ashes

The ash collection compartment must be emptied regularly so as to impede combustion residue from arriving at the brazier support. Ashes must be placed in a metal container with a sealed lid. Until ashes are completely out, the sealed container should be placed on a non-combustible base or on the floor, or well away from combustible materials.

CAUTION: ashes keep embers on for a long time!!!

9.3 Cleaning the ash container

The ash container must be emptied regularly (approximately once a month). For ash disposal, see paragraph 9.2 of the Installation, operation and maintenance Manual. **CAUTION:** when the ash container is full, the display shows **AL 8**. At the end of the operation, check that the ash container is correctly positioned.

CAUTION: risk of burns, let the ashes cool down before emptying the container. (See the images below)

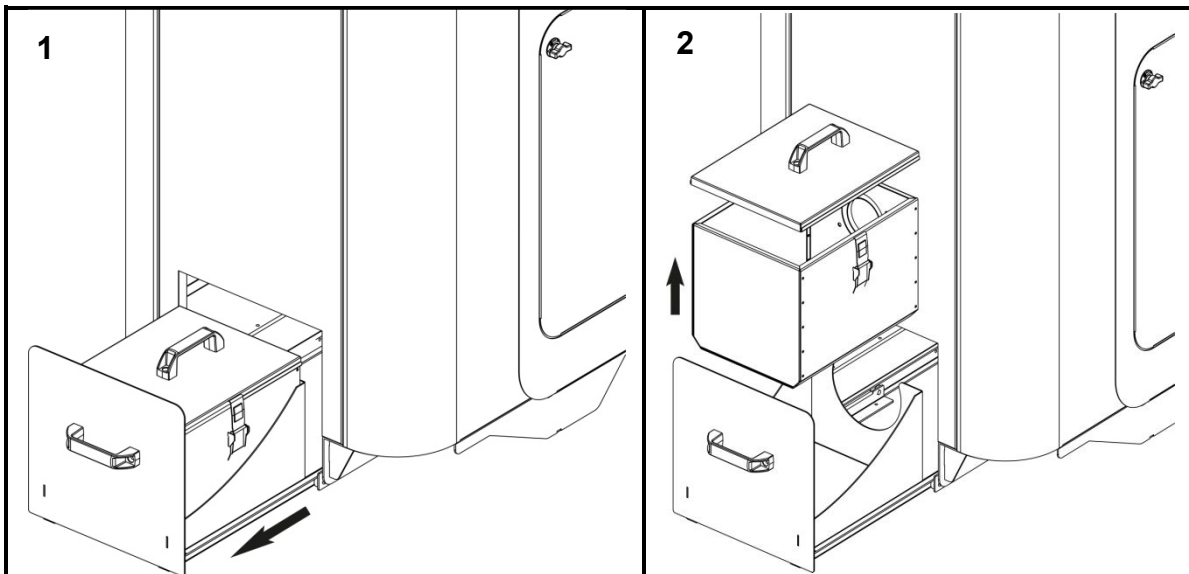

9.4 Brazier cleaning

The TERMOBOILER OMNIA 32 boiler is equipped with the CSS (Circular combustion system) proprietary brazier with rotating cleaner, which cleans the brazier automatically and drops the ash and residues in the lower compartment. The CCS auto-cleaning brazier does not require routine maintenance, however should you notice a red or weak flame, followed by black smoke, we recommend having the boiler and its installation checked by an authorised technician.

Special maintenance of the brazier: to be scheduled yearly with the CAT technician (see paragraph 9.14 Routine and special maintenance of the installation, operation and maintenance Manual).

9.5 **Combustion chamber cleaning**

Clean the combustion chamber weekly, removing ashes accumulated in the chamber using a vacuum cleaner.

NOTE A vacuum cleaner designed for the suction of ashes is required for this type of cleaning.

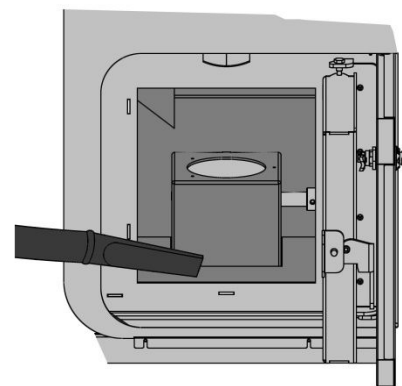

9.6 **Smoke chamber cleaning**

To clean the smoke chamber, a manual movement is arranged on the turbolator unit inside the smoke chamber. Generally, clean the smoke chamber once a year (preferably at the beginning of the season) for best boiler operation. The frequency of this operation depends on the type of pellet used and the frequency of use.

Contact a Technical Support Centre for this type of cleaning.

9.7 **Exhaust system cleaning**

Until you are reasonably experienced regarding operating conditions, it is advisable to perform this service at least monthly. Remove the T-fitting cap and proceed with duct cleaning. If necessary, at least the first few times, request assistance from a qualified technician.

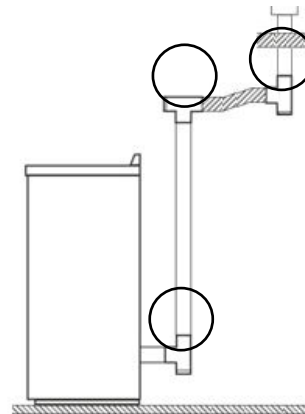

9.8 **Cleaning metal and ceramic parts**

Use a soft cloth moistened with water to clean metal boiler parts

Never clean metal or ceramic parts with alcohol, diluting agents, petrol, ketones or other degreasers.

Use of these substances frees the company from all liability.

Discolouration of metal parts can be the result of improper use of the boiler.

9.9 **Cleaning the glass**

The door's glass must be cold cleaned with ammonia-based and non-corrosive degreasers, such as a diluent. Prevent corrosive substances from coming into contact with the paint on the boiler as these can cause damage. If the glass is hot, before cleaning, keep the door open as long as necessary until it cools down. Do not use any material that can scratch or damage the glass.

9.10 **Glass breakage**

The boiler is equipped with 4 mm thick ceramic glass that is resistant to a thermal shock of 750°C. This glass may only break due to a strong impact or misuse. Do not slam the door or hit the glass. In case of breakage, replace with an original replacement part only.

Contact a Technical Support Centre to replace.

9.11 Replacing the remote control battery

Replace the old battery with a type *CR2025 3V* new one paying attention not to invert the polarity (*polarity is shown on the remote control sheet*), then re-close the remote control and dispose of the old battery according to the regulations in force.

The installed battery must be the type specified above. Failure to comply with these instructions may create an explosion hazard.

9.12 Cleaning the smoke fan

CAUTION: all cleaning and/or maintenance operations must be performed with the POWER OFF.

The boiler is equipped with fans (room and fumes) located at the lower rear of the boiler. Any deposits of dust or ash on fan blades lead to an imbalance which causes noise during operation. Fans must therefore be cleaned at least once annually. As this operation involves the removal of some boiler parts, **have the fan cleaned by a Technical Support Centre or qualified personnel only.**

9.13 Boiler inactivity

At the end of the season, perform the following operations:

- Remove the whole pellet from the tank and from the feed screw;
- Thoroughly clean the brazier, the brazier support, the combustion chamber and the ash drawer;
- Thoroughly clean the smoke exhaust system: contact a professional chimney sweep for this purpose;
- Clean all dust, spider webs, etc., the area behind the panels of the inner cladding, specifically the fans.
- Disconnect the power cable;
- Leave the fire door ajar to avoid humidity from getting into the fumes duct and risk oxidising the inner surfaces.

9.14 Routine and special maintenance

These operations must be scheduled **yearly** with a Technical Support Centre and are required to ensure the product is kept efficient and ensure safe operation.

- Thoroughly clean the combustion chamber and the heat exchanger;
- Smoke motor cleaning, dismantling and cleaning the smoke exhaust duct, new silicone where required;
- Inspection and checking the gasket seals, replacement and silicone application where required;
- Tank, emptying and cleaning;
- Checking the electrical part and electronic components;
- Cleaning and checking the tube and vacuum gauge;
- Checking and replacing, if required, of components that are subject to wear: brazier, resistance, ash drawers, etc.
- In models with DHW production, we recommend having the exchanger undergo yearly maintenance to remove limestone sediments and mineral salts.



Dasa-Räger
EN ISO 9001 (2000)
IQ-0502-09

Laminox S.r.l. Divisione Idro
Zona Industriale Callarella, 261/263 – 62028 SARNANO (MC) Italy
Tel. +39 0733.657.622 – Fax +39 0733.657.494
www.laminox.com e-mail: idro@laminox.com